

1	2		3	4		5	6	7			
THICKNESS	MATERIAL		FINISH		REV	LINE	ZONE	NAME	DATE	DESCRIPTION	
0.032" DIA	302 STAINLESS STEEL WIRE		NONE		-8			J. ANDERSON	05-JAN-2016	ORIGINAL RELEASE	

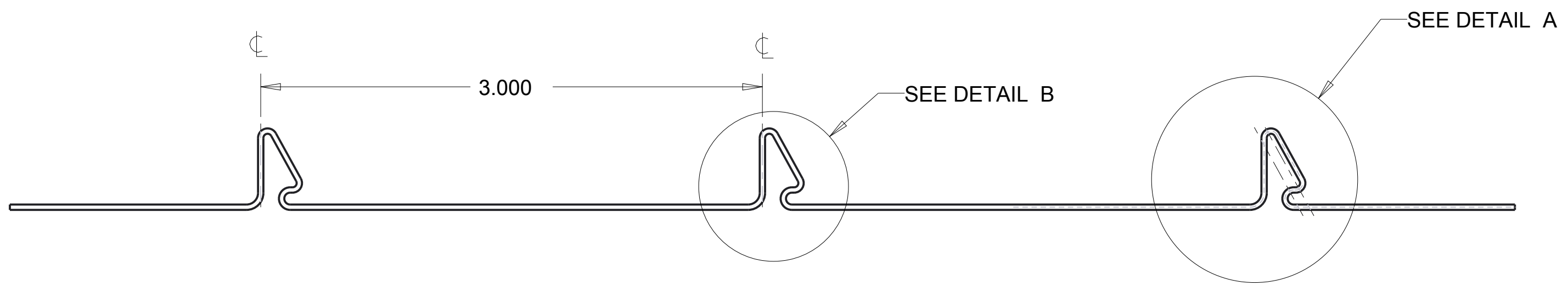
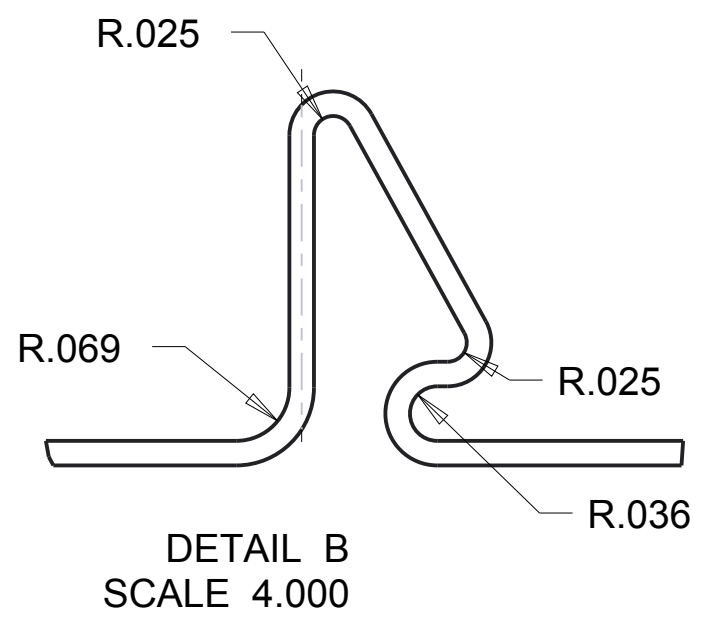
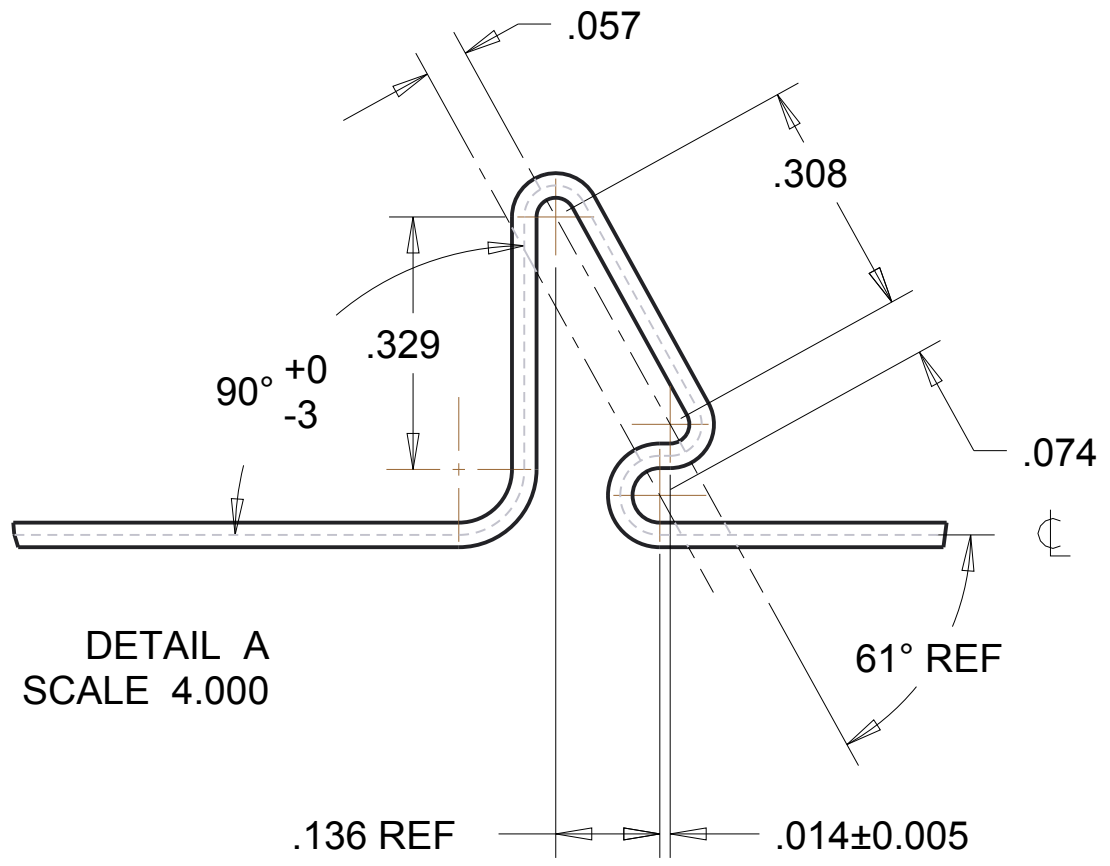

	QTY	LENGTH
L1		
L2		
L3		25 FT

TOLERANCES UNLESS OTHERWISE SPECIFIED .XXX ± 0.010 .XX ± 0.03 .X ± 0.1 ANG ± 3.0 SHEETMETAL BENDS AND FRACTIONS ±1/16 GEOMETRIC DIMENSIONING & TOLERANCING PER ANSI Y14.5M-1982 ALL DIMENSIONS IN INCHES UNLESS NOTED	DESCRIPTION: -		APPR	DATE
	PART NAME: WIRE_CLIP		ME	
	DRAWN: J. ANDERSON	DATE: 05-Jan-2016	EE	
	THIRD ANGLE PROJECTION		MFG	
DO NOT SCALE DRAWING		COMPUTER GENERATED		SIZE
		DRAWING: WIRE_CLIP		B
		SCALE: 1.59 : 1	SHEET: 1 of 1	