



TYPE CLUB NOTES

Removing and installing a prop on a Continental tapered-shaft engine, from the Luscombe and Cub Club newsletters

Bob Gehring and Steve Krog

Vintage Editor's Note: Bob Gehring and Steve Krog have done the vintage community a great service by carefully putting these procedures together in an easy-to-understand manner. Let there be no more damaged prop hubs!—HGF

Have you ever rummaged through the many piles of used parts at a typical fly market and spotted a prop hub for a tapered-shaft Continental engine? For those of you with a tapered-shaft engine, you may think you've just found a jewel among the junk and can't wait to begin bartering for the hub.

But upon closer inspection, the hub appeared to have been used as a battering ram at some point in its long life. The prop hub nut is beaten and battered, and if you had a straight edge in your pocket, you'd probably find that neither the inner nor the outer face plates of the prop hub would be flat. The prop hub nut is probably unusable. And these hubs are getting hard to find! Especially at a reasonable price.

All of this battering or hammering was unnecessary, had the previous owner used the correct procedures for removing or installing the hub in the first place.

The following information and photos will explain how to properly remove and install a tapered-shaft prop hub without doing damage to it. Those of you with a lot of experience in hub removal and replacement may have other procedures that you follow. And, if so, we'd like to hear from you.

Prop Hub Removal

Before beginning the process, *safety first*. Make sure the magneto switch and the fuel valve are in the "OFF" position and the airplane is firmly chocked. Then *disconnect* all of the spark plug leads from the spark plugs. Remember, you may be rotating or rocking the prop, which could lead to the engine firing if safety procedures are not followed.

The first step is to remove the skullcap-style spinner if you have one installed on your airplane. The two prop bolt nuts holding the spinner-mounting bracket will also have to be removed for complete access to the prop hub.

Next, remove the safety-locking bolt from the hub.

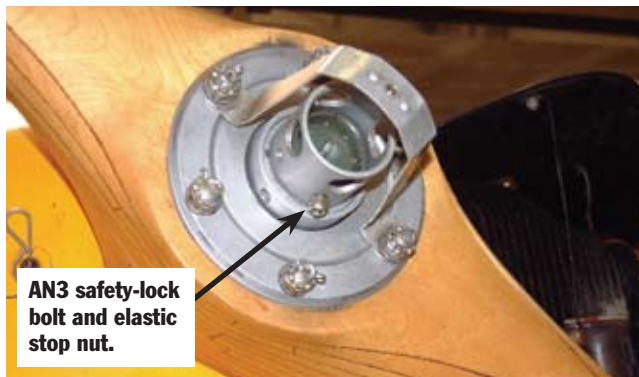

AN3 safety-lock bolt and elastic stop nut.

After removing the skullcap spinner, remove the spinner-mounting bracket. Then remove the AN3 safety-lock bolt.

This is usually an AN3 bolt held in place with an elastic stop nut.

Now, insert a 5/8-inch by 4-inch Grade 8 bolt (or a high-strength steel rod of the approximate same dimensions) through the large round locking nut on the hub. We like to use a bolt because the bolt head helps prevent slipping when applying pressure to the locking nut. Slide a 30- to 36-inch piece of 3/4 inch pipe over the length of the exposed bolt.



A 5/8-inch by 4-inch Grade 8 bolt is inserted through the prop hub locking nut. Note that the spinner-mounting bracket has been removed for complete access to the hub.

You're now ready to do a little grunting. If the prop hub locking nut has been installed correctly, it will have approximately 200-225 foot-pounds of torque that has to be broken or loosened. While having someone hold the prop firmly in place, apply pressure to the



The Grade 8 bolt has been inserted from the lower right to the upper left position in the hub nut, and a 30-inch length of 3/4-inch pipe has been slipped over the extended portion of the bolt. This position is used for ease in applying downward pressure on the pipe to loosen the hub nut.

pipe to break the nut loose, turning the nut no more than about one-quarter to one-half turn. As you face the prop hub, turn the locking nut counterclockwise.

Before proceeding further, look directly into the prop hub and locate the large retaining snap ring. It should be about 1/4 inch inside of the outer hub ring. Insert a snap ring retention device (see retention device description below) into the open gap of the snap ring. This is important. If you do not do this, the pressure that will be applied to loosen the locking nut will force the snap ring to pop free. Should this happen, stop. Pop the snap ring back into place before proceeding any further. The snap ring must remain in place during prop hub removal to help pop the hub free of the crankshaft. If you do not do this, the hub nut simply turns free and can be removed from the prop hub, leaving the hub firmly attached to the crankshaft.

We use a small homemade tool to keep the snap ring in place. It was made from a scrap piece of .090-inch chromoly steel approximately 3 inches long, tapered and slightly bent into an arc to fit in the snap ring slot.

With the snap ring retention tool in place, proceed with rotating the pipe extension handle counterclockwise, which was slid over the 4-inch steel bolt inserted in the prop hub locking nut. As you rotate the pipe extension

handle through approximately two to two-and-a-half turns, you should feel the prop hub pop. It is now free of the tapered shaft and can easily be slid off of the crankshaft when the prop hub locking nut is turned all the way out to the end of the threads.

NOTE: If you do not feel the prop hub pop free after two to two-and-a-half turns, STOP. It will be necessary to tap on the hub to help break it free.

To break the prop hub free without doing any damage to the prop hub locking nut (remember the hub you spotted at the fly market and how it was battered and bent on the end), insert a length of solid steel shaft inside the prop hub locking nut. The steel shaft we used was machined from a piece of 1-3/4-inch stock approximately 4 inches long. About .600 inch of one end was machined down to approximately 1.55-inch diameter to fit snugly inside the prop hub nut. It should slide into the hub nut, with the shoulder of the 4-inch steel shaft mating flush with the flat surface of the hub nut and should not bottom out against the crankshaft end.



The snap ring retention tool has been inserted into the snap ring opening, and the pipe extension is in place. The prop hub nut is now ready to be rotated counterclockwise approximately two to two-and-a-half turns.

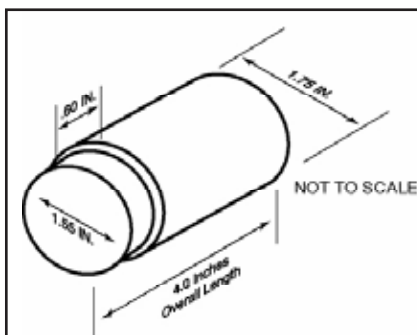

We made this tool for helping to remove the prop hub whenever a bit of persuasion was needed to pop the hub free from the tapered shaft. We started with a piece of 1-3/4-inch solid steel rod approximately 4 inches long. One end was machined or necked down to approximately 1.55 inches in diameter so it fit snugly inside the prop hub nut. The machined portion should be no longer than approximately .600 inch so it does not touch or bottom out against the threaded end of the crankshaft.

BEND THIS PORTION IN ARC TO MATCH PROP LOCKING NUT.

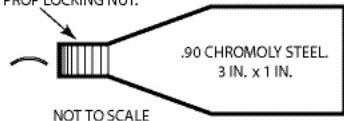

The snap ring insert we used is made of a scrap piece of .090-inch chromoly steel 3 inches long and about 1 inch wide at the widest end. It is tapered and bent slightly in an arc equal to the arc of the prop locking nut. Grind or file the end of the tool to fit snugly into the snap ring gap.



This photo clearly shows the snap ring tool in place and the steel rod inserted into the locking hub nut. Note how the outer diameter of the steel rod rests firmly against the outer flat surface of the hub nut.



While applying light pressure to the back side of the prop, insert the steel shaft into the hub nut and tap lightly with either a rubber mallet or lead hammer. The light pressure prevents the crankshaft journals from banging against the engine case when applying the light tapping to the inserted steel shaft.



Once the hub has popped free and the hub nut turned counterclockwise until free of the crankshaft threads, the prop can be guided off the shaft.

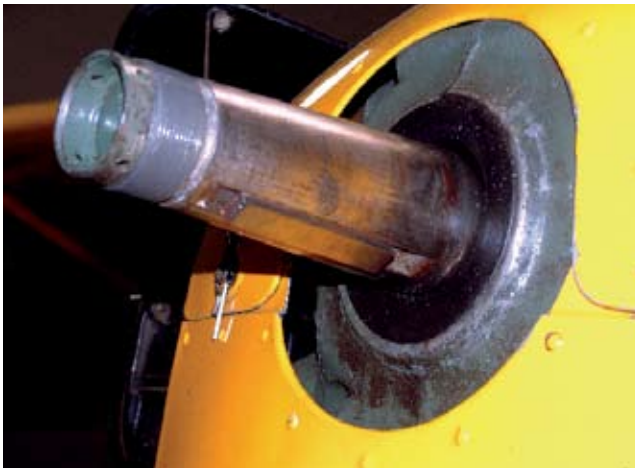

The exposed tapered crankshaft should be inspected for corrosion, then thoroughly cleaned and lightly lubricated for prop installation.

While applying light pressure or tension to the back side of the prop, insert the 4-inch steel rod into the locking nut. Tap lightly on the steel rod using either a rubber mallet or a lead hammer to break it loose. One or two light taps is all that should be needed.

Once the prop hub has popped free, turn the locking nut the remainder of the way out until it is free of

the threads on the crankshaft, and with a firm grip on the prop, gently guide the prop and prop hub off the tapered shaft.

You've now removed the prop hub without doing any damage.

Prop Hub Installation

Before installing the prop and prop hub on the tapered crankshaft, inspect the crankshaft and the prop hub for dirt and corrosion. Old grease, dirt, etc., can easily be removed using a good cleaning agent such as lacquer thinner or mineral spirits; a 3M cleaning pad; and a good, clean cotton rag.

Caution: If using lacquer thinner, be careful to not splash it on the noseowl, the outer surfaces of the prop hub, or the prop itself, for it will also remove paint and varnish, allowing a place for corrosion or wood rot to start.

Once the tapered crankshaft and the inner prop hub have been thoroughly inspected and cleaned, use a light lubricant, such as 3-in-1 oil, to completely lubricate the entire surface of each. Do not use an excess of the light lubricant. More is not better in this case, as any excess will be slung out, causing unsightly streaks on the back and front hub plates.

With both surfaces cleaned and lightly lubricated, you can now start the installation process. Begin by first locating the locking keyway on the tapered shaft. With a firm grip on the prop, locate the mating keyway slot on the hub and position the prop in front of the shaft, aligning the hub keyway with the shaft keyway.

Slide the aligned prop and prop hub onto the shaft. Don't force it. It should slide freely onto the shaft. Then start the prop hub locking nut and finger-tighten it.

Snug down the locking nut using the 4-inch long Grade 8 bolt used to loosen the prop hub nut and the 30- to 36-inch length of pipe. Do not overtighten at this point; just snug it firmly.

Now it is time to properly tighten the hub locking nut to the correct 200 to 225 foot-pounds of torque pressure. This is the one step that is most often done incorrectly when installing a tapered shaft prop hub, as most people don't have the correct tools for executing. Rather, they'll guesstimate the torque by literally hanging on the pipe extension or by getting a longer extension to make sure it's good and tight. Over the years we've found this to be the case when trying to break loose a prop nut. It was so overtightened, it was nearly impossible to break loose. This causes undue stress loads on the hub and shaft, creating a situation for cracking and rendering the hub useless.

Using the special socket described (above right), insert the socket into the hub locking nut. Align the holes with the holes in the locking nut and insert the 4-inch Grade 8 bolt through the nut and socket. You now have an easy-to-use socket for correctly torquing the locking nut. Using a torque wrench, begin tightening the locking nut, beginning at about 150 foot-pounds, and work your way up to the desired 200 to 225 foot-pounds.



We use another homemade tool for correctly torquing the prop hub nut, as it does require 200 to 225 foot-pounds of torque for proper installation. This tool is made using a 1/2 inch drive 1-1/16-inch socket. A flat washer, used for rigidity, is welded over the open socket end. Then a 5/8-inch diameter hole is drilled completely through the socket.

Remove all cotter pins from the six prop bolts (two were already removed when the skullcap spinner and spinner-mounting bracket were removed), and loosen all nuts. Install the spinner bracket, and snug the nuts, holding it in place to finger-tight.



The specially designed hub socket has been inserted into the hub locking nut and the Grade 8 bolt inserted through the nut and socket. This setup allows for properly torquing the hub nut using a torque wrench.

Using the proper method for re-torquing the prop bolts, begin torquing the bolts to the desired 16 to 19 foot-pounds. Again, use the step-up method, beginning at approximately 10 to 12 foot-pounds, and work your way up to the desired 16 to 19 foot-pounds. (We use 18 foot-pounds on our wooden props.)

After torquing to proper values, allow the prop and hub to sit for 10 to 15 minutes and then re-torque again.

Now, check the propeller for proper tracking. See the September/October *Cub Clues* No. 124, page 10, for step-by-step details. (*Vintage Editor's Note: These instructions will also be published in the April 2005 issue of Vintage Airplane.*)

The final step is then to install the cotter pins and skullcap spinner.

NOTE: Sensenich recommends that its wooden props should have its torque values checked periodically, especially if the aircraft is kept in a climate that experiences significant seasonal changes.

The installation of the prop hub is now complete, and torque values are accurate, assuring long life for that valuable tapered shaft prop hub. However, the job is not yet finished.

Now is also a good time to check and re-torque the prop bolts. Remember, with the seasonal changes in temperatures and humidity, that beautiful (and expensive) wooden prop shrinks and swells accordingly, requiring re-torquing of the prop bolts.

Remove all cotter pins from the six prop bolts (two were already removed when the skullcap spinner and spinner-mounting bracket were removed), and loosen all nuts. Install the spinner bracket, and snug the nuts, holding it in place to finger-tight.



The special socket is in place, and correct torque values are now applied to the hub nut.

This is an overhead view of the four special tools we made and use when removing and installing prop hubs on tapered-shaft Continental engines.



- The item at left is the 4-inch by 1 3/4-inch solid steel rod with one end machined down to 1 1/2-inch. Machine down approximately 3/4-inch of the end of the rod. This is the portion that will be inserted into the hub nut and should not bottom out against the end of the crankshaft.

- The second item is the 5/8-inch by 4-inch Grade 8 bolt.

- The third item is the special tool made from .090-inch chromoly stock inserted into the snap ring gap.

- The final item is the 1/2-inch drive 1 1/16-inch socket with a flat washer welded over one end. A 5/8-inch hole is drilled through the socket.



An Old Friend Is Back

Just Like in the Good Old Days

All the Randolph products, all the Randolph colors, all the Randolph quality. An aviation icon is back on the market again... to stay.

800-362-3490

Or e-mail us at info@randolphaircraft.com

