



SureFly Ignition Module

SIM4P

4 Cylinder Impulse Magneto Replacement

INSTALLATION INSTRUCTIONS

Document No. SF1001, Revision B

Revision History

| Revision: | Date: | Description: | Approved By: |
|-----------|------------|---|--------------|
| IR | 05/21/2018 | Initial release. | JDH |
| A | 06/18/2018 | Added page numbers, revised section 3, included drawings SIM4P & SIM4P-INSTALL. | JDH |
| B | 07/26/2018 | Reformatted for clarity & added illustrations. | RVC |

Contents

| | |
|---|----|
| Contents..... | 2 |
| 1. Installation Overview | 3 |
| 1.1. General Description: | 3 |
| 1.2. Operation: | 4 |
| 1.3. Technical References: | 4 |
| 2. Step-By-Step Installation Instructions | 5 |
| 2.1. Eligibility Determination:..... | 5 |
| 2.2. Component List: | 5 |
| 2.3. Preparation:..... | 6 |
| 2.4. Remove Magneto:..... | 6 |
| 2.5. Remove & Inspect Drive Interface: | 7 |
| 2.6. Install Drive Interface: | 7 |
| 2.7. Configure SIM: | 8 |
| 2.8. Set Engine to #1 TDC: | 9 |
| 2.9. Internally Time SIM: | 9 |
| 2.10. Mount SIM to Engine: | 10 |
| 2.11. SIM Timing Check:..... | 10 |
| 2.12. Connect SIM to Permanent Power Source:..... | 10 |
| 2.13. Install Ignition Harness:..... | 11 |
| 2.14. Manifold Pressure Connection:..... | 11 |
| 2.15. Install P-Lead: | 11 |
| 3. Post-Installation | 12 |
| 3.1. Spark Plugs & Harness:..... | 12 |
| 3.2. Final Inspection: | 12 |
| 3.3. Pre-Operational Check: | 12 |
| 3.4. Operational Check: | 13 |
| 4. Documentation | 13 |
| 4.1. STC Permission Letter:..... | 13 |
| 4.2. FAA Form 337:..... | 13 |
| 4.3. Maintenance Log:..... | 13 |
| 4.4. ICA: | 13 |

1. Installation Overview

1.1. General Description:

The **S**ureFly **I**gnition **M**odule (SIM) is a magneto replacement for Continental & Lycoming aircraft piston engines.

The SIM is designed to use existing aviation spark plugs gapped to OEM specifications.

The SIM is designed to use a “Slick” style ignition harness. If replacing a “Slick” magneto, the existing harness may be re-used. If replacing any other magneto, or for a new installation, an approved “Slick” style ignition harness is needed. Although not required, SureFly recommends installing a new harness when installing a SIM.

The SIM is designed to use existing magneto-to-engine drive gears and interfaces.

The SIM operates in one of two modes:

1. Advance timing mode – timing advances based on RPM and Manifold Absolute Pressure (MAP), or
2. Fixed timing mode – engine data-plate timing maintained throughout operational range.

UNLIKE A MAGNETO, THE SUREFLY SIM IS TIMED (SYNCED) TO #1 CYLINDER COMPRESSION STROKE TDC (0°).

The SIM references #1 cylinder compression stroke TDC (0°) and advances timing within the unit based on its dip switch setting.

The SIM requires a constant, external supply of 8.5 – 30VDC power to operate.

SureFly provides a power wire PN 4&6C601 and an Airframe STC you may use to connect the SIM to a permanent power source.

For information on SureFly’s airframe STC please see www.surefly.aero/airframe

This manual covers only the engine installation of the SIM.

1.2. Operation:

The SIM operates like a magneto.

When the SIM is configured to operate in advance timing mode, the SIM will only advance beyond fixed engine timing under specific RPM and MAP conditions. Up to 38° of advance may be reached by the SureFly SIM.

To operate the SIM in advance timing mode, the engine onto which the SIM is installed must comply with the following requirements:

1. Normally aspirated,
2. Have Cylinder Head Temperature (CHT) monitoring capability,
3. Use minimum of 100-octane low lead aviation fuel.

If the installation does not have equipment to monitor cylinder head temperatures, if the engine is equipped with a turbo or super charger, or if the engine operates on any fuel other than 100LL, you must configure the SIM for fixed timing mode.

SureFly recommends starting the engine on the SIM. The SIM provides a more accurately retarded spark than an impulse coupled magneto at low engine RPM. This alleviates the need for an impulse coupled magneto or supplemental starting equipment like "Shower of Sparks".

1.3. Technical References:

The following documents may be referenced during the installation of the SIM:

1. SureFly SIM4P Installation Instructions: SF1001 (this document),
2. SureFly Overview Drawing: SIM4P,
3. SureFly Hardware Kit Drawing: SIM4P-HW,
4. FAA Advisory Circular 43.13-1b Acceptable Methods, Techniques, and Practices.

Copies of these documents may be found at www.surefly.aero/engine

2. Step-By-Step Installation Instructions

2.1. Eligibility Determination:

Before commencing, you as the owner or installer must determine whether the SIM is approved for installation on the intended engine. SureFly's STC has an Approved Model List (AML) that shows eligible engines.

FIRST: Determine whether your engine is listed on SureFly's engine STC AML. A copy of the AML may be found at www.surefly.aero/engine

If your specific engine (entire model designation) is listed on the AML, you may proceed.
If your engine is NOT listed on the AML, stop now and contact SureFly.

SECOND: Determine whether any previously installed STC's conflict with the installation of the SIM. Such might include:

1. FADEC systems,
2. Fuel STC's that allow the use of fuel other than 100LL,
3. Aftermarket turbo or super chargers.

If no conflicting STC's are found, you may proceed.

If any previously installed STC's may conflict with the installation of the SIM, stop now and contact SureFly.

2.2. Component List:

The following items are needed to install the SIM to an engine. They should be included in the box:

1. SureFly Ignition Module: SIM4P,
2. SIM4P Hardware Kit: SIM4P-HW,
3. These installation instructions: SF1001.

If any documents are missing, you may find copies at www.surefly.aero/engine

Please contact SureFly if any items are found damaged.

2.3. Preparation:

READ AND UNDERSTAND ALL OF THE INSTRUCTIONS BEFORE BEGINNING INSTALLATION.

a) Familiarize yourself with the terminals and ports of the SIM:

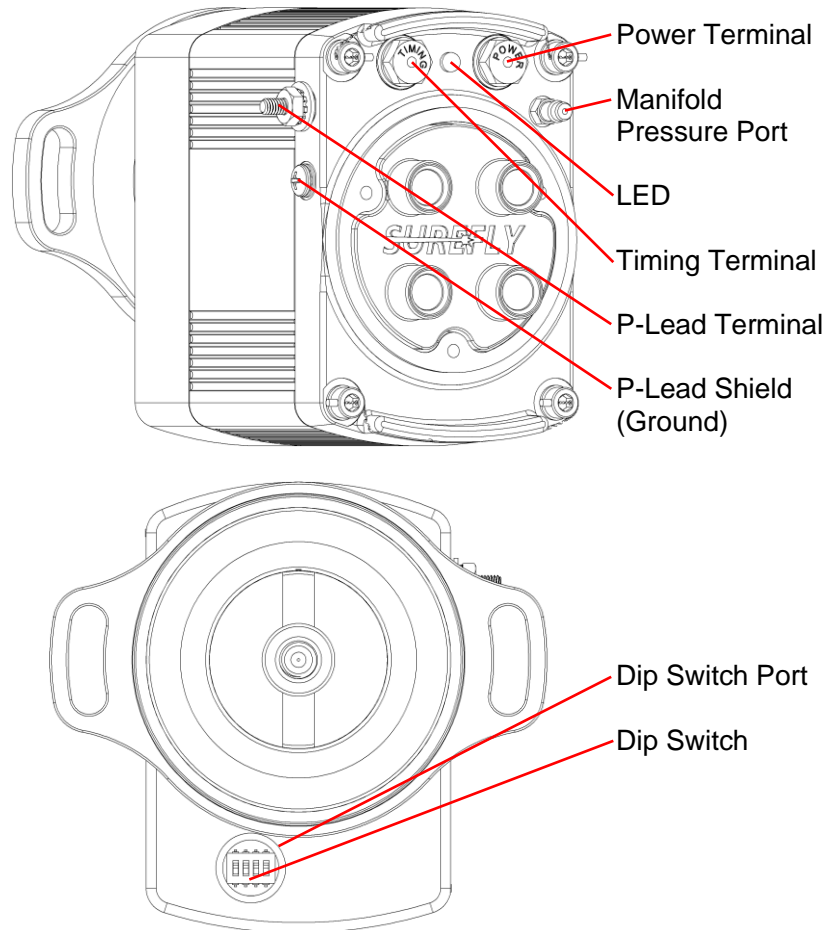

SIM Terminals and Ports

2.4. Remove Magneto:

- a) Remove one spark plug from #1 cylinder.
- b) Label the running p-lead wire connected to the magneto being replaced.
- c) Remove the existing ignition harness by removing the screws securing the cap to the magneto.
- d) Remove p-lead and ground (if present) from magneto being replaced.
- e) Remove magneto from engine by removing the nuts, washers and clamps securing it to the engine. Some of this hardware will be re-used to install the SIM.
- f) Impulse spacer P/N 61666 will be re-used. Do not remove the spacer from the engine unless replacement of the engine-to-spacer gasket is planned (this gasket is not included).
- g) If replacing engine-to-spacer gasket, remove, clean and replace it now.
- h) Remove and discard the magneto gasket and clean all gasket residue from the mounting surface of the spacer. The SIM is sealed with an o-ring and a gasket is not required.

2.5. Remove & Inspect Drive Interface:

- a) Remove cotter pin, nut and washer and extract drive gear from magneto.
- b) Inspect drive gear per manufacturer's recommendations.
- c) If drive gear is out of specifications, discard and replace with an airworthy drive gear and proceed.
- d) If drive gear is within manufacturer's specifications, proceed.

2.6. Install Drive Interface:

- a) The drive gear fits on the SIM shaft in one of two orientations. A normal installation will align a gear tooth valley with the machined dot on the SIM shaft:

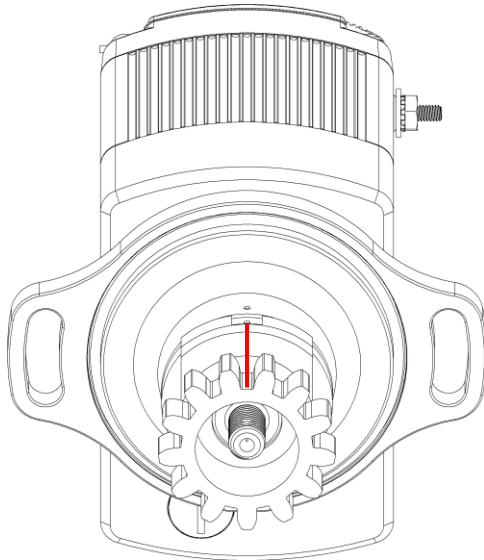

Normal Drive Gear Orientation

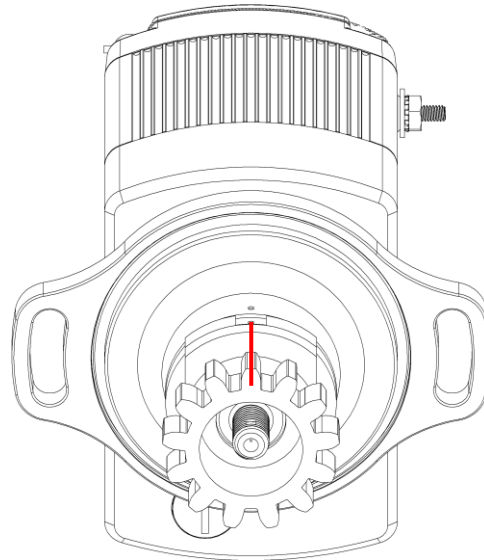

Alternate Drive Gear Orientation

- b) If you have difficulty timing the SIM to the engine in further steps, it may be necessary to remove the drive gear from the SIM and re-install it 180° on the shaft as shown in the alternate orientation.
- c) Place washer under castellated nut and thread nut onto shaft.
- d) Torque the castellated nut to 120-180 inch-lbs. Tighten to align the castellated nut to the hole in the shaft. Do not exceed 250 inch-lbs.
- e) Lock castellated nut with cotter pin in accordance with AC 43.13-1b.
- f) Ensure locked cotter pin end does not extend beyond the forward face of the drive gear.

2.7. Configure SIM:

- Find the data-plate on the engine and note the timing value listed for the magneto being replaced.
- Record the timing value here: ___ ° Before Top Dead Center (BTDC).
- The SIM4P recognizes both Left and Right rotation and does not need to be configured for direction.
- Find the matching engine timing value in the table below. Move across the row and select whether the SIM is to operate in advance or fixed timing mode to find the appropriate dip switch setting.

| Engine Timing | Timing Mode | Dip Switch | | | | LED Code |
|---------------|-------------|------------|-----|-----|-----|----------|
| | | 1 | 2 | 3 | 4 | |
| 30° | Advance | OFF | ON | ON | ON | ---- |
| | Fixed | ON | ON | ON | ON | ---- |
| 28° | Advance | OFF | ON | ON | OFF | ---- |
| | Fixed | ON | ON | ON | OFF | ---- |
| 26° | Advance | OFF | ON | OFF | ON | ---- |
| | Fixed | ON | ON | OFF | ON | ---- |
| 25° | Advance | OFF | ON | OFF | OFF | ---- |
| | Fixed | ON | ON | OFF | OFF | ---- |
| 24° | Advance | OFF | OFF | ON | ON | ---- |
| | Fixed | ON | OFF | ON | ON | ---- |
| 22° | Advance | OFF | OFF | ON | OFF | ---- |
| | Fixed | ON | OFF | ON | OFF | ---- |
| 20° | Advance | OFF | OFF | OFF | ON | ---- |
| | Fixed | ON | OFF | OFF | ON | ---- |
| 18° | Advance | OFF | OFF | OFF | OFF | ---- |
| | Fixed | ON | OFF | OFF | OFF | ---- |

- Record the derived dip switch setting and its LED code identifier here:

| Dip Switch Setting: | | | |
|---------------------|---|---|---|
| 1 | 2 | 3 | 4 |
| | | | |
| LED Code: | | | |
| | | | |

- Unscrew the dip switch port plug and set it aside.
- Using a pick or small screwdriver, carefully reach into the dip switch port on the SIM and set the dip switch to match the setting recorded above.
- Ensure switches required to be ON are set UP toward the SIM shaft, and switches required to be OFF are set DOWN away from the SIM shaft.
- After setting the SIM dip switch, double check that the switch reflects the setting recorded in e) above.
- Apply medium strength thread-locking compound to the threads of the plug and screw it into the dip switch port. Torque the plug to 20±2 inch-lbs.

2.8. Set Engine to #1 TDC:

- a) Rotate the engine to find top dead center (TDC - 0°) of #1 cylinder on the compression stroke.

2.9. Internally Time SIM:

- a) You must internally time the SIM to align the drive gear before installing the SIM into the engine.
- b) Connect a temporary source of positive (+) 8.5 – 30VDC power to the terminal labelled TIMING on the SIM using the provided screw. Finger tighten the screw.
- c) Ground the SIM to the negative (-) lead of the temporary power source. Do not attempt to ground through painted or anodized surfaces – ground through the machined mount face, p-lead shield terminal or case bolt heads.

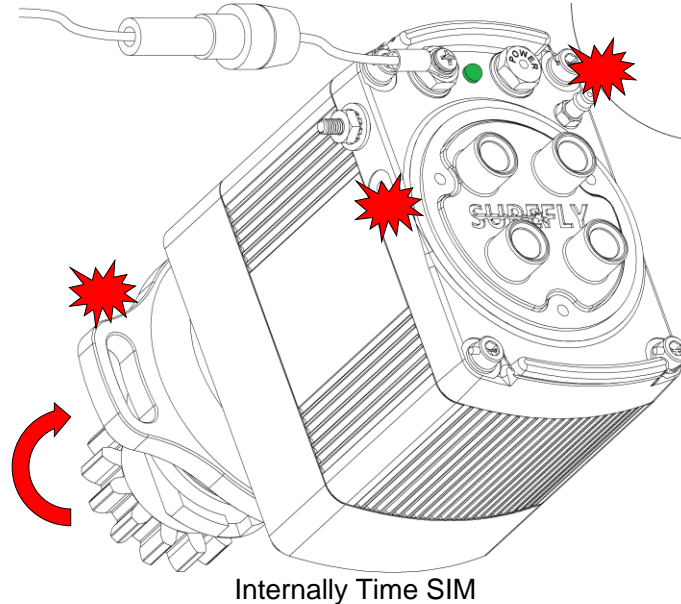

- d) The SIM LED should illuminate green. If not, wiggle the drive gear, re-ground the SIM and ensure the SIM p-lead terminal is not grounded.
- e) **The SIM LED will not turn on if the p-lead terminal is grounded.**
- f) Slowly rotate the SIM drive gear to find the point where the LED extinguishes.
- g) **TURN SLOWLY – the LED alignment point has a ½° window and is difficult to see if turning fast!**
- h) The point at which the LED extinguishes is the SIM's internal TDC alignment.
- i) Once this point is found, care should be taken to avoid any rotation of the SIM drive gear during further steps of engine installation.

2.10. Mount SIM to Engine:

- a) The SIM operates by syncing its internal TDC alignment point to #1 cylinder compression stroke (TDC – 0°) and advances timing within the unit based on its dip switch setting.
- b) **Confirm the engine is at top dead center (TDC - 0°) of #1 cylinder on the compression stroke.**
- c) Ensure the o-ring is present, free of debris and seated in the SIM face groove.
- d) Ensure the SIM is still internally timed as described in 2.9 above.
- e) **Without allowing the SIM drive gear to rotate**, align the SIM mounting ear slots with the engine studs and slide the SIM into the magneto cavity.
- f) Holding the SIM flush to the engine, clock the SIM to ensure the LED extinguished point is within the rotational sweep limits of the mounting ear slots.
- g) Repeat steps c) through f) above if unable to find the LED extinguished point as the SIM drive gear may have skipped a tooth over the engine gear when pushed in.
- h) If **still unable** to find the LED extinguished point, reinstall the drive gear to the alternate drive gear orientation as described in 2.6 and begin over from 2.9.a).
- i) Install flat washers, lock washers & nuts on to the engine studs over the SIM's slotted mounting ears. Do not re-use lock washers – install NEW lock washers.
- j) **Do not use the clamps that some magnetos are installed with.**
- k) Finger tighten the nuts, barely allowing the SIM to rotate by hand.
- l) Clock the SIM to ensure the LED stays extinguished.
- m) At this point the SIM is timed (synced) to the engine.
- n) Torque the mounting nuts to 150 – 160 inch-lbs ensuring the LED stays extinguished.

2.11. SIM Timing Check:

- a) Turn the engine counter to normal rotation 1/8 of a turn from #1 cylinder TDC.
- b) Slowly rotate the engine in the normal direction.
- c) If the LED extinguishes more than 2° before or after #1 cylinder TDC, the SIM is incorrectly timed and is not in sync with the engine. Loosen the SIM mounting nuts and re-clock the SIM per 2.10.f) through 2.10.n).
- d) If the **LED extinguishes as #1 cylinder reaches TDC – 0°** (compression stroke) the SIM is correctly timed (synced) to the engine and you may proceed.

2.12. Connect SIM to Permanent Power Source:

- a) Remove the temporary power source from the TIMING terminal of the SIM.
- b) Connect a permanent source of positive (+) 8.5 – 30VDC power to the POWER terminal of the SIM using the provided screw.
- c) Tighten the screw to 10±2 inch-lbs.
- d) The wire connecting the SIM to the permanent power source should be at minimum 14AWG, Mil-Spec (MIL-W-22759 / M22759 / SAE AS22759) wire, circuit protected at 10A and as short as possible.
- e) SureFly provides a power wire PN 4&6C601 that you may use for this purpose.
- f) The SIM grounds through the engine. Ensure the negative (-) lead of the permanent power source is connected to the engine.

2.13. Install Ignition Harness:

- a) The SIM is designed to use a “Slick” style ignition harness.
- b) If replacing a “Slick” magneto, the existing harness may be re-used.
- c) If replacing any other magneto, or for a new installation, an approved “Slick” style ignition harness is needed.
- d) Although not required, SureFly recommends installing a new harness when installing a SIM.
- e) Confirm the correct harness is being used and is free of defects.
- f) Install the harness onto the SIM using the provided screws.
- g) Torque the screws to 18±2 inch-lbs.

2.14. Manifold Pressure Connection:

- a) The SIM **does not require** a connection to the engine’s manifold pressure (MAP) system to operate in **fixed timing mode**. Cap the SIM manifold pressure port with the provided cap (or other suitable cap) and skip forward to the next section.
- b) The SIM **does require** a connection to the engine’s manifold pressure system to operate in **advance timing mode**.
- c) Recommended sources of manifold pressure include:
 1. Intake port on cylinder head,
 2. Existing manifold pressure plumbing,
 3. Intake manifold plenum.
- d) Install one end of the provided manifold pressure hose over the barbed manifold pressure port on the SIM.
- e) Route and connect the other end of the hose to a manifold pressure source.
- f) Secure the tubing along its route being sure not to pinch, kink or impede tubing airflow.

2.15. Install P-Lead:

- a) Install the p-lead wire from the ignition switch onto the SIM p-lead terminal.
- b) Thread provided nut over SIM p-lead terminal. Back p-lead base nut with a wrench and torque the nut to 15±2 inch-lbs.
- c) If the p-lead wire is shielded, connect the shield to the p-lead shield (ground) terminal with the provided screw and torque to 15±2 inch-lbs.
- d) **Important Note:** If you are replacing a shower of sparks magneto, install the wire labeled “Advance” on the P-Lead terminal of the SIM. Do not use the wire labeled “Retard” – insulate this wire and tie it back.

3. Post-Installation

3.1. Spark Plugs & Harness:

- a) Re-install the spark plug into #1 cylinder. Torque to manufacturer's specifications.
- b) Connect ignition harness to spark plugs ensuring all wires are routed to the correct cylinders. Torque to manufacturer's specifications.

3.2. Final Inspection:

- a) Visually inspect the following items:
 1. SIM mounting hardware present and torqued,
 2. Power wire is connected and secure at SIM power terminal,
 3. Ignition harness and spark plugs installed and torqued,
 4. Manifold pressure hose secure at MAP source and SIM MAP terminal,
 5. All wires, hoses and harnesses are properly secured along their entire route.

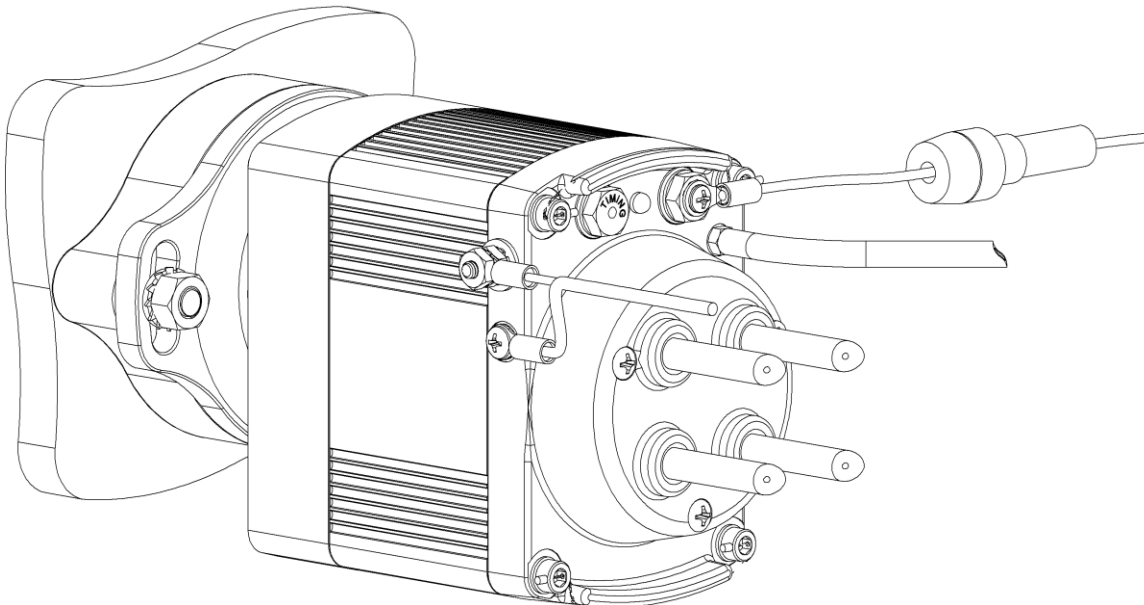

Typical SIM4P Installation

3.3. Pre-Operational Check:

- a) Ensure the ignition switch is turned off (p-lead grounded).
- b) Clear the propeller area.
- c) Turn the ignition switch on (p-lead un-grounded) and verify SIM LED illuminates and blinks.
- d) The SIM LED will blink the code set by the SIM dip switch. The code will repeat for 4 cycles before the LED goes inactive. Cycle the ignition switch to see the LED code again.
- e) Verify the code blinked by the SIM LED matches the code recorded in 2.7.e).
- f) The code must exactly match the intended SIM timing setting. If the code differs, remove the SIM and start over from 2.7.a).
- g) If the LED blinks rapidly at 12 blinks/second, stop and contact SureFly.

3.4. Operational Check:

- a) Start the engine normally using the engine manufacturer's recommended starting procedure.
- b) Contact SureFly If the engine does not run smoothly on the SIM.

4. Documentation

4.1. STC Permission Letter:

- a) You must obtain a letter of permission from SureFly Partners, LTD before completing the engine STC.
- b) Please visit www.surefly.aero/engine to view and print a copy of SureFly's STC permission letter.

4.2. FAA Form 337:

- a) You must file a FAA Form 337 to notify the FAA of the alternation to the engine in accordance with SureFly's engine STC, engine AML, engine ICA and these Installation Instructions.
- b) Please visit www.surefly.aero/engine to view and print a copy of SureFly's engine STC documents.

4.3. Maintenance Log:

- a) You must document the alteration to the engine in the engine's maintenance records and/or logbooks.
- b) Please see www.surefly.aero/engine for an example of a logbook entry.

4.4. ICA:

- a) The Instructions for Continued Airworthiness for the SIM may be found at www.surefly.aero/engine