

GENERAL SPECIFICATIONS	
IGNITION TYPE	WASTED SPARK
MAX. INPUT RPM	3500 RPM
OPERATING TEMPERATURE RANGE	-38°C TO +107°C
VOLTAGE INPUT RANGE	8.5 - 30 V _{DC}
OPERATING POWER REQUIREMENTS @ 2700 RPM	0.70±0.2 A @ 14 V _{DC} 0.35±0.2 A @ 28 V _{DC}
MANIFOLD PRESSURE INPUT RANGE	5 - 45 inHg
TIMING ACCURACY	±2°
BUILD	surefly_4_18041701.zip
CHECKSUM	0057E5CD

REVISIONS				
ZONE	REV.	DESCRIPTION	DATE	APPROVED
ALL	PT-1	PROTOTYPE 1	04/14/2017	RVC
ALL	PT-2	PROTOTYPE 2	06/01/2017	RVC
ALL	IR	INITIAL RELEASE FOR PRODUCTION	05/21/2018	RVC

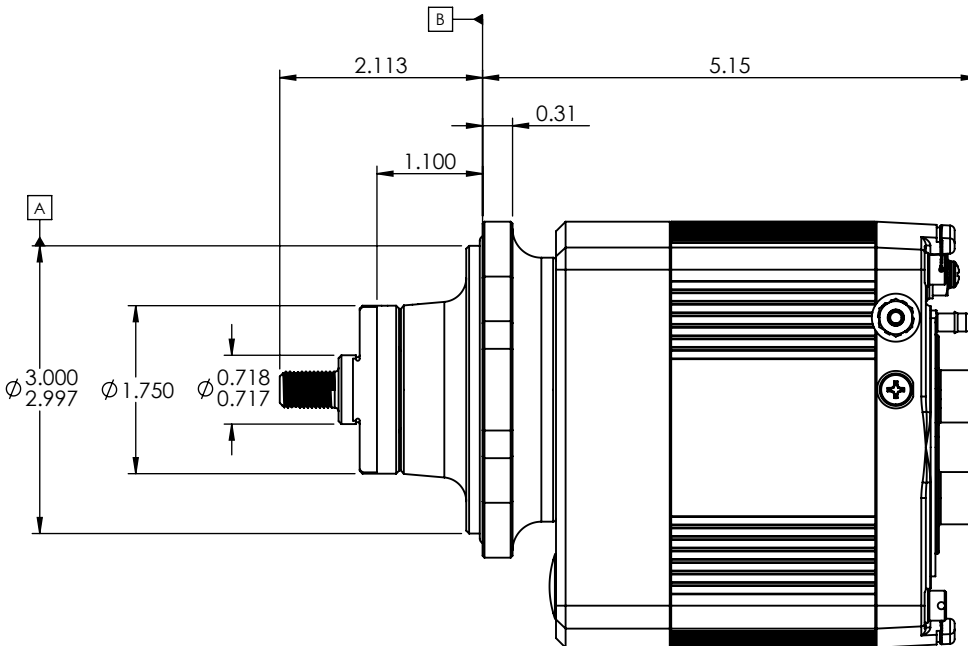
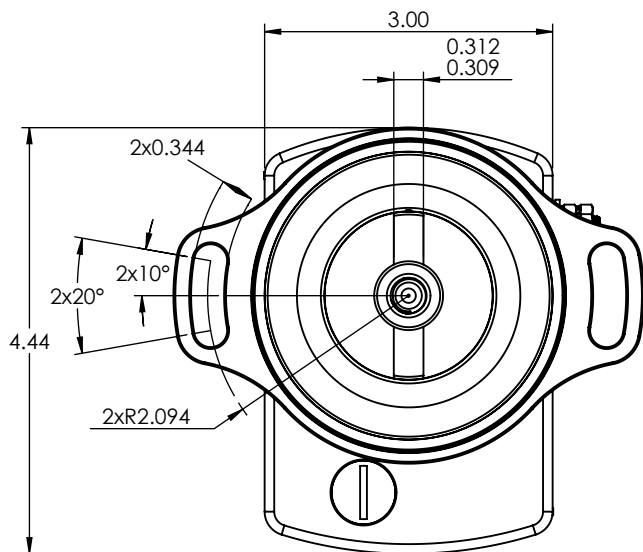

DIP SWITCH SETTINGS

ENGINE TIMING	TIMING OPTION	DIP SWITCH				LED CODE	TIMING SCHEDULE
		1	2	3	4		
		<small>30° ON-ON-ON-ON 28° ON-OFF-ON-ON 26° ON-OFF-ON-ON 24° ON-OFF-ON-ON 22° ON-OFF-ON-ON 20° ON-OFF-ON-ON 18° OFF-OFF-OFF-OFF</small>				<small>ON=SHORT OFF=LONG 12/SECOND ERROR</small>	
30°	ADVANCED	OFF	ON	ON	ON	----	A-30
	FIXED	ON	ON	ON	ON	----	F-30
28°	ADVANCED	OFF	ON	ON	OFF	----	A-28
	FIXED	ON	ON	ON	OFF	----	F-28
26°	ADVANCED	OFF	ON	OFF	ON	----	A-26
	FIXED	ON	ON	OFF	ON	----	F-26
25°	ADVANCED	OFF	ON	OFF	OFF	----	A-25
	FIXED	ON	ON	OFF	OFF	----	F-25
24°	ADVANCED	OFF	OFF	ON	ON	----	A-24
	FIXED	ON	OFF	ON	ON	----	F-24
22°	ADVANCED	OFF	OFF	ON	OFF	----	A-22
	FIXED	ON	OFF	ON	OFF	----	F-22
20°	ADVANCED	OFF	OFF	OFF	ON	----	A-20
	FIXED	ON	OFF	OFF	ON	----	F-20
18°	ADVANCED	OFF	OFF	OFF	OFF	----	A-18
	FIXED	ON	OFF	OFF	OFF	----	F-18

FIRING ORDER

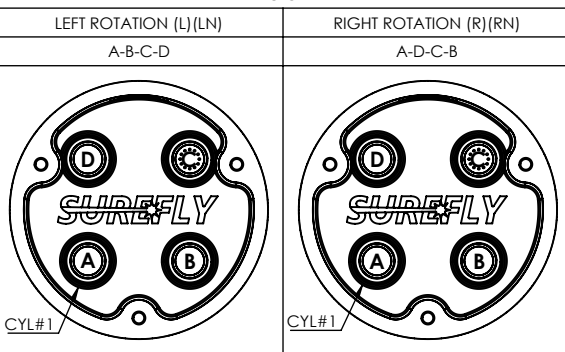

SureFly
Granbury, Texas

4 CYLINDER IMPULSE COUPLER IGNITION

SCALE: 1:2	MATERIAL: N/A	FINISH: N/A
DIMENSIONS IN INCHES UNLESS OTHERWISE SPECIFIED		DRAWN BY: R. CONDY
TOLERANCES:		DATE: 05/21/2018
ANGLES ±1°	0.X ±0.050	0.XX ±0.030
	0.XXX ±0.010	
SHEET: 1/1		PART NO: SIM4P
REV: IR		