

**ILLUSTRATED PARTS CATALOG  
FOR  
C-75, C-85, C-90 & O-200  
AIRCRAFT ENGINES**

**FORM X30011A**

**FAA APPROVED  
FEBRUARY 1981**

# TABLE OF CONTENTS

STATUS PAGES .....	iii/iv
SECTION I	
INTRODUCTION .....	1-1
LIST OF ABBREVIATIONS .....	1-1
USABLE ON CODE .....	1-2
ACCESSORY MANUFACTURERS .....	1-3/1-4
SECTION II	
Figure 1 - Crankcase Studding Assembly .....	2-2
Figure 2 - Crankcase Attaching Parts .....	2-4
Figure 3 - Crankcase Associated Parts .....	2-6
Figure 4 - Crankcase Assembly - Tapered .....	2-8
Figure 5 - Crankcase Assembly - Flanged .....	2-9
Figure 6 - Connecting Rod Assembly .....	2-10
Figure 7 - Piston Assembly .....	2-10
Figure 8 - Camshaft Assembly, Lifters & Push Rods .....	2-11
Figure 9 - Cylinder Assembly .....	2-12
Figure 10 - Crankcase Cover Assembly .....	2-14
Figure 11 - Crankcase Cover Assembly .....	2-16
Figure 12 - Carburetor Induction Assembly .....	2-18
Figure 13 - Starter and Generator .....	2-20
Figure 14 - Starter Generator, Voltage Regulator .....	2-21
Figure 15 - Bendix Ignition System (S4LN-21, S4RN-21) .....	2-22
Figure 16 - Slick Ignition System ( Model 447) .....	2-24
Figure 17 - Oil Cooler Equipment .....	2-26
Figure 18 - Fuel Pump Equipment .....	2-26
Figure 19 - Oil Sump Assemblies .....	2-28
SECTION III	
OVERSIZE AND UNDERSIZE PARTS LIST .....	3-1
SECTION IV	
REPAIR PARTS SETS AND MATERIALS .....	4-1/4-2
SECTION V	
NUMERICAL PARTS LIST .....	5-1
SECTION VI	
CUSTOMER SPECIFICATIONS .....	6-1
Figure 20 - Cover, Vacuum Pump Pad .....	6-6
Figure 21 - Flange Exhaust .....	6-6
Figure 22 - Relay .....	6-6
SECTION VII	
O-200-B BASIC AND CUSTOMER SPECIFICATIONS .....	7-1
Figure 23 - Cover, Vacuum Pump Pad .....	7-3/7-4
Figure 24 - Flange, Exhaust .....	7-3/7-4

# CURRENT STATUS OF PAGES AS OF

## FEBRUARY 1981

THE ORIGINAL DATE OF THIS PUBLICATION IS FEBRUARY, 1981  
INSERT LATEST PAGES, DESTROY SUPERSEDED PAGES.

MODELS C75, C85, C90 & O200 PARTS CATALOG FORM X30011A

PAGE	STATUS	PAGE	STATUS	PAGE	STATUS	PAGE	STATUS
i thru iv	Original						
1-1 thru 1-4	Original						
2-1 thru 2-30	Original						
3-1 thru 3-2	Original						
4-1 thru 4-2	Original						
5-1 thru 5-10	Original						
6-1 thru 6-6	Original						
7-1 thru 7-4	Original						



# SECTION I

## INTRODUCTION

1-1. In line with the Teledyne Continental Motors program of product improvement, this parts catalog is presented in looseleaf form. Changes will be issued as they occur to those pages which are affected only. In this manner the parts catalog will be kept current at all times, with manufacturing and service requirements. All changes to the catalog will be sent to the purchaser upon receipt of the registration card from the front of the catalog.

1-2. Page iii of this publication depicts the current status of pages as of the date listed. To be current, the date on the page should match the date listed for that page on the Status Page, when a change occurs, otherwise a page with no date is unchanged. With each change to the catalog issued, a change to the current Status Page will necessarily be issued.

1-3. In this edition, currently available parts are listed for Models C75, C85, C90 and O-200 engines. If accessories or parts attached to any engine installed in an aircraft manufactured in the United States under production model number do not appear in this catalog, determine whether they are available from the aircraft manufacturer before placing an order with a Teledyne Continental Authorized Distributor

1-4. Since the first edition was published the Teledyne Continental four cylinder "C" series engines have been expanded several times. This series currently includes the C75, C85 and C90 in the -8, -12, -14 and -16 configuration and the O-200.

All engines in recent years have been produced with flanged crankshaft, indicated by an "F" following the engine number on the nameplate, i.e., C75-8F. The number 8, 12, 14 or 16 indicates the equipment included on the engine. A -8 has no starter or generator. A -12 is equipped with these two items. A -14 is the same as a -12 plus "Lord" type engine mountings. A -16 has a provision for a vacuum

pump, in addition to the foregoing. The O-200 engine incorporates all of these features

1-5. Section II contains 19 figures, in each of which one of the major assemblies or groups of the engine is illustrated in "exploded" form. Each figure has its own set of index numbers to indicate the sub-parts. The list of parts in the assembly or group appears on the same page with the illustration or on an adjacent page. The first column of each assembly or group list contains the figure number (not repeated on all lines) and, following a dash, the index number of the sub-parts in numerical order. Do not order parts by index number. Use the part number, which appears in the second column. Use the name of the part which appears in column under the title "Description".

1-6. Do not order any parts listed herein when "Not Sold", herein abbreviated "NS" appears in the "Units Per Assy" column. These parts are not suitable for installation without factory equipment, or they are major parts of assemblies and are more economically supplied in the assembled condition, or they are assemblies which would have to be *disassembled for installation. To replace any detail part "Not Sold" order the smallest assembly containing the part (listed above, with the name beginning one column to the left). To replace any assembly "Not Sold", order whatever assemblies and detail parts (listed below it, with names indented), that are in need of replacement.*

1-7. Quantities of parts, as listed in Section II, are for specific application in one assembly. Total quantities for all parts are listed in Section V. Similar assemblies listed in Section II are combined, and quantities of sub-parts are for one assembly. Application code letters in the last column indicate on which models assemblies and sub-parts are used. Sub-parts have the same code letter as their parent assembly.

1-8. Oversize and Undersize parts are listed in Section III. These parts must be ordered by the numbers listed herein, with correct descriptions, to avoid errors. Corresponding standard size part numbers in Section II are preceded by a symbol (†) to indicate the availability of the non-standard size. (Refer to the list of abbreviations and symbols.)

1-9. Sets of parts listed in Section IV, are usually wanted in such groups for overhaul work and should be ordered by set part numbers.

1-10. Section V contains a list of part numbers arranged in numerical order in the first column. If the number of any desired part is known, the name may be located by referring to the figure and index number in Section II, which is listed

opposite the number in Section V. Quantities listed are total requirements for one engine.

1-11. Section VI contains a parts listing of customer specifications of the basic engines of the O-200-A. Only the differences between the customer specification and the basic engine are shown.

Only those specifications which were sold in quantities of 25 or more are covered herein.

1-12. Section VII contains a listing of the O-200-B and the most popular customer specifications of that engine. Only the differences between the O-200-B and O-200-A are shown.

## LIST OF ABBREVIATIONS AND SYMBOLS

SYMBOL	DEFINITION	SYMBOL	DEFINITION
AR	As required (quantity)	PD	Pitch diameter (of thread)
dia.	Diameter	Qt.	Quart
ID	Inside diameter	Ref.	Reference (or Refer to)
in.	Inches	S.A.E.	Society of Automotive Engrs.
LH	Left Hand	Sq.	Square
mm	Millimeter	US	Undersize
NPT	National pipe tap (or thread)	No.	Number
NS	Not sold	†	Oversize parts available
OD	Outside diameter	†	Undersize parts available
Opt.	Optional	* * * *	End of a group of attaching parts
OS	Oversize	\$	Parts included in a set

## USEABLE ON CODE

C75	A
C85	B
C90	C
O-200	D

## ACCESSORY MANUFACTURERS

ACCESSORY	MFG'S NO.	NAME	ADDRESS
Magneto	----- -----	Slick Model 447 Slick Model 4001	Slick Electro Rockford, Illinois
Magneto	10-51360-6 10-51360-1	Scintilla Model S4RN-21 Scintilla Model S4LN-21	Bendix Corporation Sidney, New York
Starter Generator Voltage Regulator	1109656 1101890 1118736	Delco-Remy Delco-Remy Delco-Remy	United Motors Service General Motors Building Detroit, Michigan
Carburetor	-----	Stromberg Model NA-S3A1	Aircraft Technical Service Bendix Corporation South Bend, Indiana
Carburetor	10-4252  10-4115	Marvel Schebler Model MA-3SPA Marvel-Schebler Model 84240	Borg-Warner Corporation Flint, Michigan
Alternator	-----	Ford	Ford Motor Company General Parts Division Ypsilanti, Michigan
Alternator	-----	Prestolite	The Presolite Company Div. of Eltra Corporation 511 Hamilton Street Toledo, Ohio 43601





**SECTION II**  
**GROUP ASSEMBLY PARTS LIST**

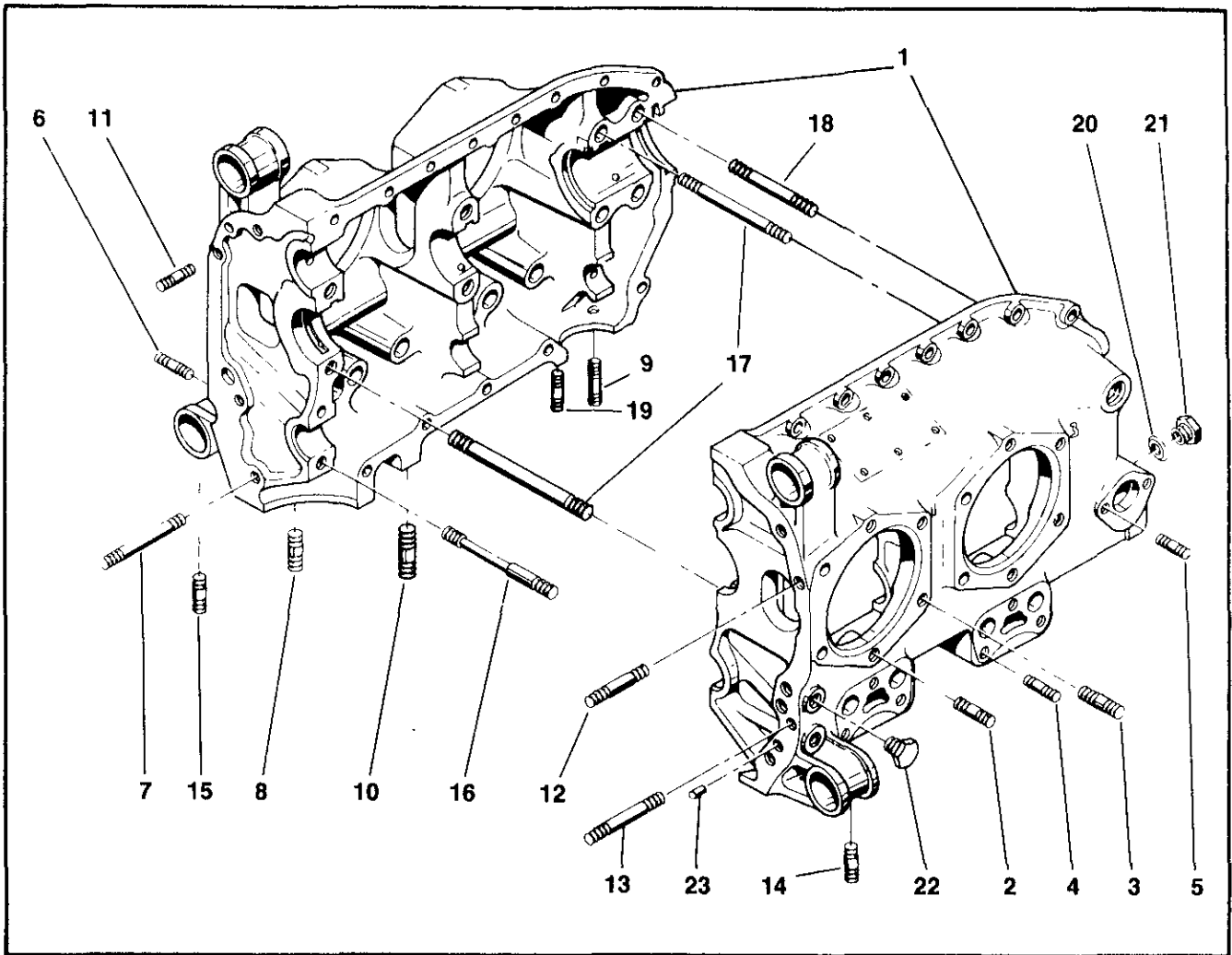

FIGURE 1. CRANKCASE STUDDING ASSEMBLY

FIG. INDEX	PART NUMBER	1 2 3 4 5	DESCRIPTION	QTY.	CODE
1-1	628195A1	①	Studding Assembly, Crankcase .....	1	A
-1	627360A2	②	Studding Assembly, Crankcase .....	1	B
-1	627359A2	③	Studding Assembly, Crankcase .....	1	C
-1	627358A2	④	Studding Assembly, Crankcase .....	1	C
-1	643250		Studding Assembly, Crankcase .....	1	D
-2	633181	†	Stud, 3/8 x 1-1/2 Inch Long .....	8	All
-3	402040	†	Stud, 7/16 x 1-1/2 Inch Long .....	8	All
-4	401804	†	Stud, 1/4 x 1-1/16 Inch Long .....	12	All
-5	402151	†	Stud, 5/16 x 1-1/4 Inch Long .....	2	ABC
-6	401809	†	Stud, 5/16 x 1-3/8 Inch Long .....	3	All
-7	402048	†	Stud, 5/16 x 3-11/16 Inch Long .....	1	AC
-8	401801	†	Stud, 1/4 x 1-3/16 Inch Long .....	3	All
-9	402151	† ①	Stud, 5/16 x 1-1/4 Inch Long .....	1	CD
-10	401977	† ②	Stud, 3/8 x 2-1/8 Inch Long .....	2	ABC
-10	402032	† ①	Stud, 3/8 x 2-11/32 Inch Long .....	2	C
-10	401954	†	Stud, 3/8 x 2-1/4 Inch Long .....	2	D
-11	401809	† ②	Stud, 5/16 x 1-3/8 Inch Long .....	10	ABC
-12	402047	†	Stud, 5/16 x 2-9/16 Inch Long .....	5	All
-13	402049	†	Stud, 5/16 x 3-3/4 Inch Long .....	2	BC
-13	402049	†	Stud, 5/16 x 3-3/4 Inch Long .....	3	D
-14	402042	†	Stud, 5/16 x 1 Inch Long .....	1	All
-14	25030	②	Stud, 5/16 x 1-1/16 Inch Long .....	1	C
-15	401881	†	Stud, 5/16 x 1-1/8 Inch Long .....	1	All
-15	25030	† ②	Stud, 5/16 x 1-1/16 Inch Long .....	1	C
-16	21075	†	Stud, 3/8 x 5 Inch Long .....	1	ABC
-16	401874	†	Stud, 3/8 x 5 Inch Long .....	1	D
-17	25329	†	Stud, 7/16 x 6-3/32 Inch Long .....	4	All
-18	25330	†	Stud, 7/16 x 3-5/8 Inch Long .....	2	All
-19	401870	† ①	Stud, 1/4 x 1-1/8 Inch Long .....	3	CD
-20	AN900-10	\$	Gasket .....	2	All
-21	532432		Plug .....	2	All
-22	2024		Plug .....	1	ABC
-22	629518-1H		Plug .....	1	D
-23	21080		Dowel .....	2	All

NOTES:

- ① Used on C90-16F.
- ② Used on C90-14F.
- ③ Used on -8 Models only.
- ④ Used on -12 Models only.

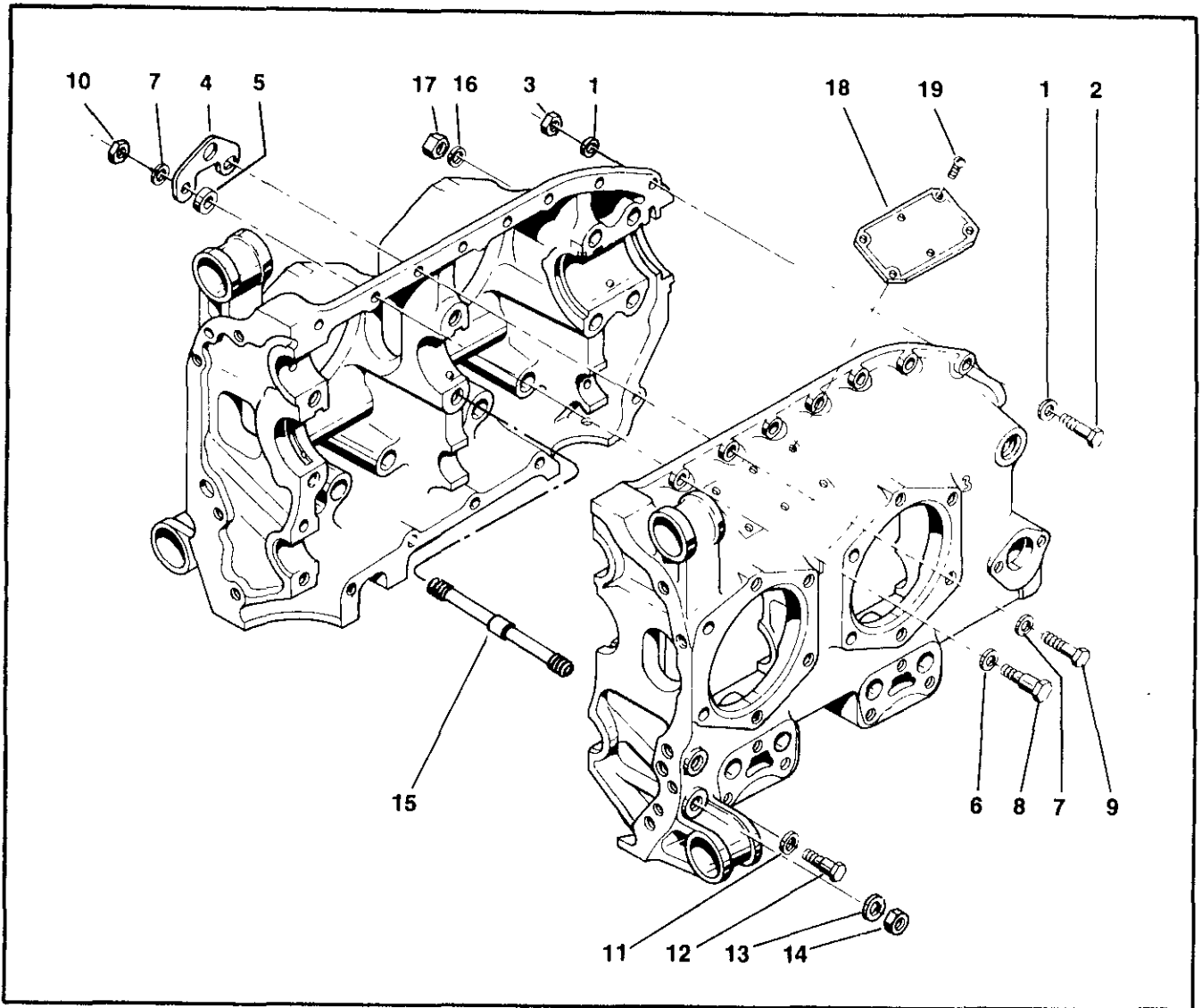

FIGURE 2. CRANKCASE ATTACHING PARTS

FIG. INDEX	PART NUMBER	1 2 3 4 5	DESCRIPTION	QTY.	CODE
2-1	20522		Washer, Plain, 1/4 Inch .....	22	All
-2	AN4-11A		Bolt, Hex 1/4 x 1-5/32 Inch Long .....	10	ABC
-2	24251		Bolt, 1/4 x 1-1/4 Inch Long .....	10	D
-3	2437		Nut, Plain 1/4 Inch .....	12	All
-4	24879		Eye, Lifting .....	1	All
			ATTACHING PARTS		
-5	25164		Washer, Special .....	2	All
-6	2472		Washer, Plain 1/4 Inch .....	1	All
-7	20522		Washer, Plain 1/4 Inch .....	3	ABC
-7	20522		Washer, Plain 1/4 Inch .....	1	D
-8	21218		Screw, 1/4 x 1-1/2 Inch Long .....	1	All
-9	24878		Screw, 1/4 x 1-5/8 Inch Long .....	1	All
-10	2437		Nut, Plain .....	2	All
			* * * *		
-11	2472		Washer, Plain 1/4 Inch .....	2	All
-12	24252		Screw, 1/4 x 1-1/4 Inch Long .....	2	All
-13	401507		Washer, Plain 25/64 Inch .....	1	All
-14	2441		Nut, Plain, 3/8 Inch .....	1	All
-15	627275		Bolt, Thru, 7/16 x 10-39/64 Inch Long .....	2	All
-16	2475		Washer, Plain 7/16 Inch .....	2	All
-17	2443		Nut, Plain 7/16 Inch .....	2	All
-18	* * *		Ⓢ Plate, Engine Identification .....	1	All
			ATTACHING PARTS		
-19	21007		Screw, Drive .....	6	All

NOTE:

Ⓢ Order in accordance with instructions in Service Bulletin M75-5.

Obsolete crankcases which have through studs installed at the center bearing bosses will require P/N 25329 in lieu of through bolts 627275 if replacement is required. When front end of crankcases are machined to accept 3/8 inch pipe plugs, order Part No. 2025, if replacement plug is required. Also use brass thrust washer P/N 36075 and A36074.

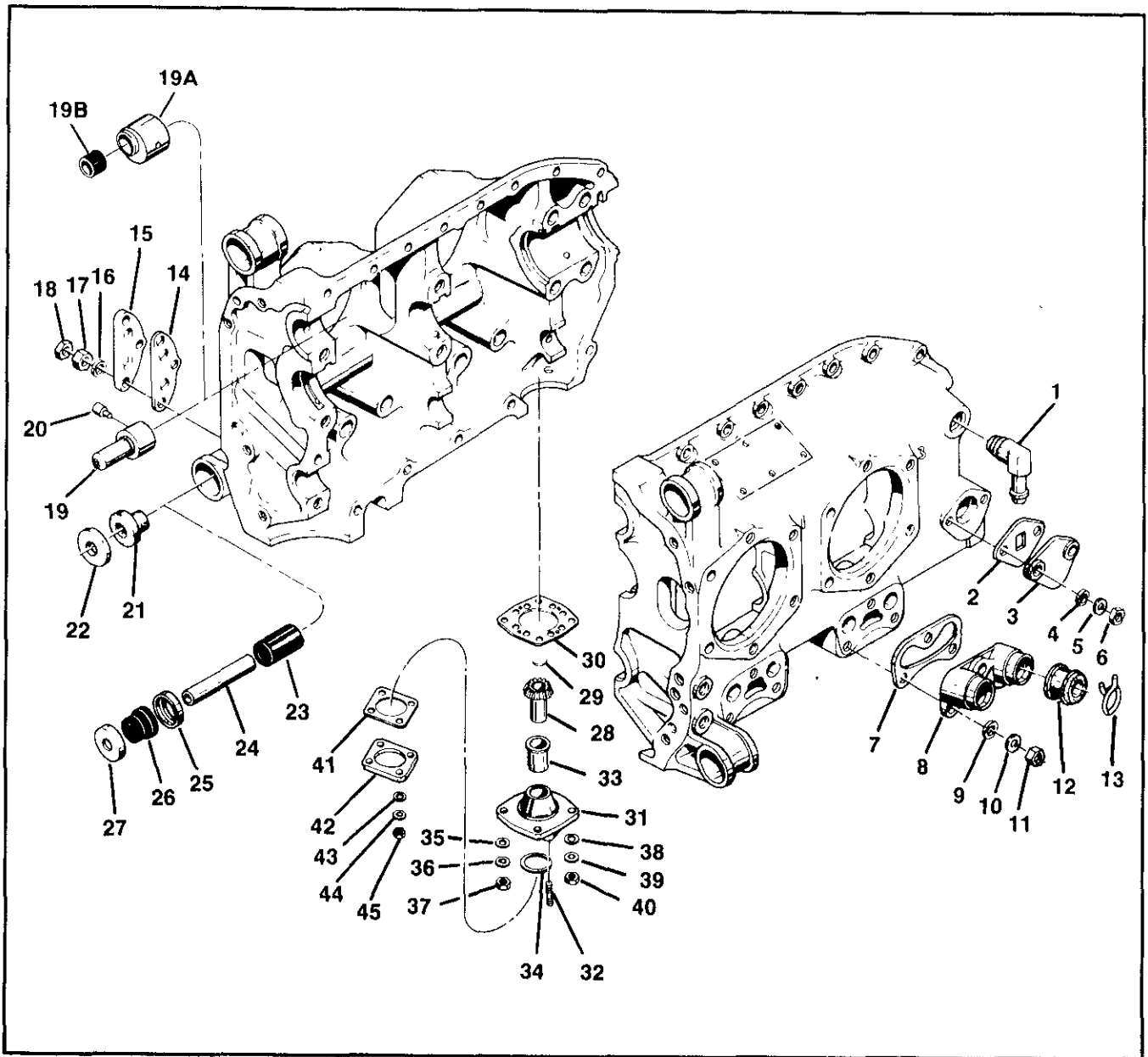

FIGURE 3. CRANKCASE ASSOCIATED PARTS

FIG. INDEX	PART NUMBER	1	2	3	4	5	DESCRIPTION	QTY.	CODE
3-1	AN842-10						Elbow .....	1	All
-2	530642	\$					Gasket .....	1	ABC
-3	533965						Cover .....	1	ABC
ATTACHING PARTS									
-4	2473						Washer, Plain 5/16 Inch .....	2	ABC
-5	MS35338-45						Washer, Lock 5/16 Inch .....	2	ABC
-6	2439						Nut, Plain 5/16 Inch .....	2	ABC

\* \* \* \* \*

FIG. INDEX	PART NUMBER	1 2 3 4 5	DESCRIPTION	QTY.	CODE
-7	530928	\$ ①	Gasket .....	4	All
-8	530163		Flange .....	4	All
ATTACHING PARTS					
-9	20522		Washer, Plain 1/4 Inch .....	12	All
-10	MS35337-44		Washer, Lock 1/4 Inch .....	12	All
-11	2437		Nut, 1/4 Inch .....	12	All
-12	539840	\$	Connector .....	8	All
-13	536388-1 25		Clamp .....	16	All
* * * * *					
-14	22344	\$	Gasket, Oil Cooler Pad .....	1	All
-15	35033	①	Cover, Oil Cooler Pad .....	1	All
ATTACHING PARTS					
-16	2473	①	Washer, Plain 5/16 Inch .....	3	All
-17	MS35337-45	①	Washer, Lock 5/16 Inch .....	3	All
-18	2439	①	Nut, Plain 5/16 Inch .....	3	All
* * * * *					
-19	23487	①	Pivot, Starter Pinion .....	1	All
-19A	643231	④②	Adapter Assembly, Starter Clutch .....	1	D
-19B	633609-8	②	Bearing, Needle .....	1	D
-20	637832	①	Dowel .....	2	All
-21	22387	\$	Bushing .....	8	All
-22	21530		Washer .....	4	All
-23	628555-16	③	Hose .....	4	CD
-24	530627	③②	Spacer .....	4	CD
-25	530626	③	Seat .....	8	CD
-26	530740	③	Bushing .....	8	CD
-27	530741	③	Washer .....	8	CD
-28	625937		Gear Assembly, Vacuum Pump Drive .....	1	D
-29	X2235		Plug, Hubbard .....	1	D
-30	626983	\$	Gasket .....	1	D
-31	625935		Adapter Assembly, Vacuum Pump .....	1	D
-32	401963	†	Stud, 1/4 x 1 Inch Long .....	4	D
-33	632330		Bushing .....	1	D
-34	25102	\$	Seal, Oil .....	1	D
ATTACHING PARTS					
-35	20522		Washer, Plain 1/4 Inch .....	3	D
-36	MS35337-44		Washer, Lock .....	3	D
-37	2437		Nut, Plain 1/4 Inch .....	3	D
-38	2473		Washer, Plain 5/16 Inch .....	1	D
-39	MS35337-45		Washer, Lock 5/16 Inch .....	1	D
-40	2439		Nut, Plain 5/16 Inch .....	1	D
* * * * *					
-41	MS9134-1		Gasket .....	1	D
-42	640380		Cover, Vacuum Pump Pad .....	1	D
ATTACHING PARTS					
-43	2472		Washer, Plain .....	4	D
-44	MS35337-44		Washer, Lock .....	4	D
-45	2437		Nut, Plain .....	4	D

NOTE:

- ① Not used on -8, -8F Models.
- ② See Section VI for specific applications.
- ③ C90-14F and O-200 Only
- ④ If Adapter Assembly, part no. 634461 is to be reworked see SB M79-10.

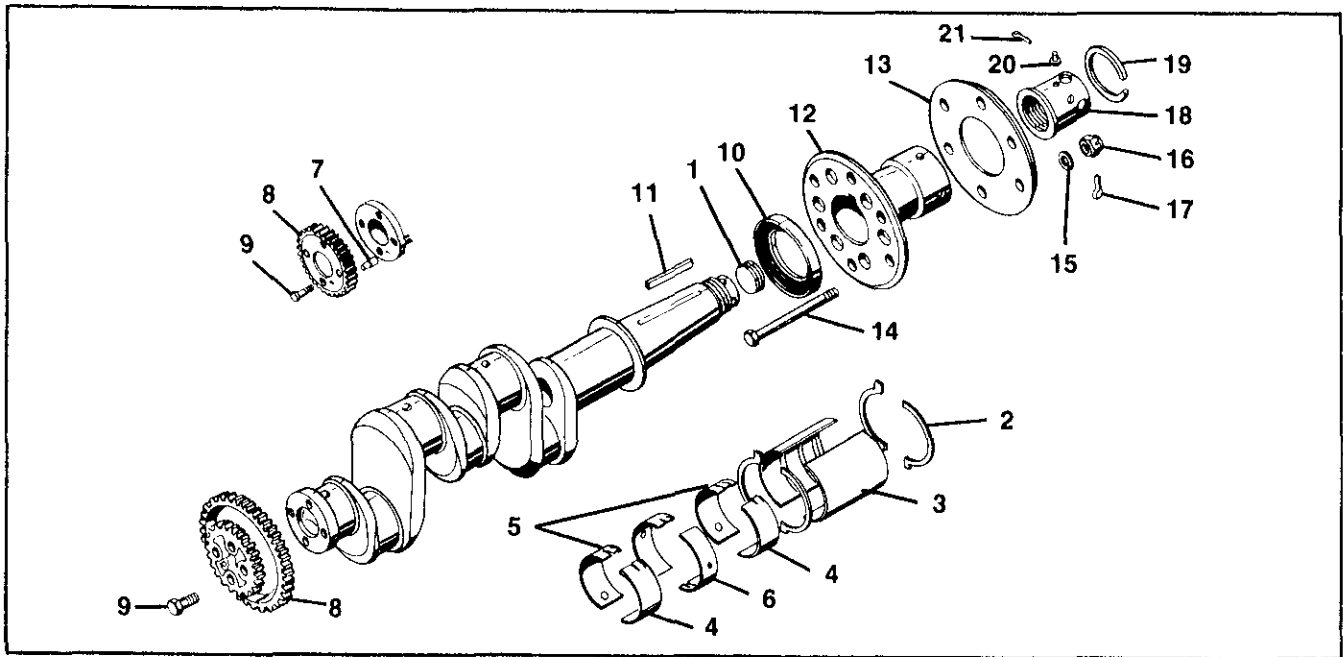

FIGURE 4. CRANKCASE ASSEMBLY - TAPERED

FIG. INDEX	PART NUMBER	1 2 3 4 5	DESCRIPTION	QTY.	CODE
4-	530196A1		Crankshaft Assembly .....	1	AB
-1	500398		. Plug .....	1	AB
-2	633141		⓪ Washer, Thrust .....	4	AB
-3	530058		† ⓪ Bearing, Front .....	2	AB
-4	633398		† ⓪ Bearing, Main Cylinder 1 & 3 .....	2	AB
-5	633399		† ⓪ Bearing, Main Cylinder 2 & 4 .....	2	AB
-6	639640		† Bearing, Connecting Rod .....	8	AB
-7	630651		† Dowel .....	1	AB
-8	35016		Gear Cluster, Crankshaft (-12) .....	1	AB
-8	530641		Gear, Cluster, Crankshaft (-8) .....	1	AB
ATTACHING PARTS					
-9	21346		Screw .....	4	AB
-9	22532		Screw .....	4	AB
* * * * *					
-10	24321		Seal, Crankshaft, Oil .....	1	AB
-11	500400		Key, Propeller Hub .....	1	AB
	A3746		Hub Assembly .....	1	AB
-12	3745		. Hub .....	1	AB
-13	3991		. Flange .....	1	AB
-14	21468		. Bolt .....	6	AB
-15	2474		. Washer, Plain 3/8 Inch .....	6	AB
-16	2458		. Nut, Castle 3/8 Inch .....	6	AB
-17	2506		. Pin Cotter .....	6	AB
-18	21202		. Nut, Propeller Hub .....	1	AB
-19	21203		. Ring, Propeller Hub .....	1	AB
-20	AN392-11		. Pin, Flat Head .....	1	AB
-21	2500		. Pin, Cotter .....	1	AB

NOTE:

⓪ See Section IV for all engine bearing kits, including sets for crankcases with dowels installed in front bearing boss and sets with dowel in thrust washer.



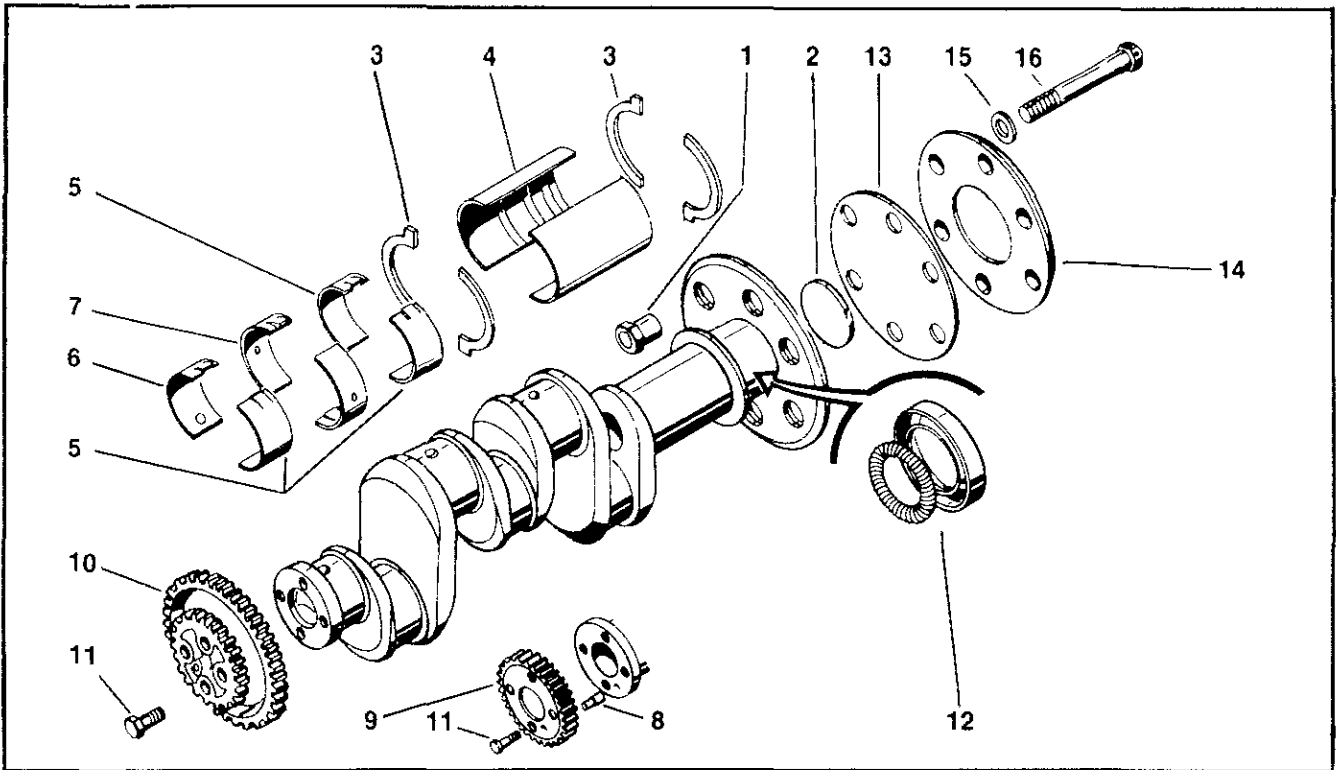

FIGURE 5. CRANKCASE ASSEMBLY - FLANGED

FIG. INDEX	PART NUMBER	1 2 3 4 5	DESCRIPTION	QTY.	CODE
5-	530199A1		Crankshaft Assembly .....	1	AB
	530182		Crankshaft Assembly .....	1	CD
-1	24769		Bushing, Prop Bolt .....	6	All
-2	24770		Plug Hubbard .....	1	AB
-3	633141		⊙ Washer, Thrust .....	4	All
-4	530058		† ⊙ Bearing, Front .....	2	All
-5	633398		† ⊙ Bearing, Main Cylinder 1 & 3 .....	2	All
-6	643233		† ⊙ Bearing, Main Cylinder 2 & 4 .....	2	All
-7	639640		† Bearing, Connecting Rod .....	8	All
-8	630651		† Dowel .....	1	All
-9	530641		⊙ Gear Crankshaft .....	1	All
-10	35016		⊙ Gear, Cluster, Crankshaft .....	1	All
ATTACHING PARTS					
-11	21346		⊙ Screw .....	4	All
-11	22532		⊙ Screw .....	4	All
* * * * *					
-12	530019		Seal Assembly, Oil .....	1	All
-13	530956		Spring .....	1	All
-14	35956		Plate, Moisture Impervious .....	1	ABC
-15	3991		Flange, Propeller Hub .....	1	ABC
-16	401507		Washer .....	6	ABC
-17	24768		Bolt .....	6	ABC

NOTE:

- ⊙ See Section VI for complete bearing kits.
- ⊙ Used on -8 Models only.
- ⊙ Used on -12, -14, -16 & O-200 Models.

FIG. INDEX	PART NUMBER	1 2 3 4 5	DESCRIPTION	QTY.	CODE
6-	A35160A2		Rod Assembly, Connecting .....	4	AB
	530184A2		Rod Assembly, Connecting .....	4	CD
-1	25369		. Bushing, Piston Pin .....	1	AB
-1	530192		. Bushing, Piston Pin .....	1	CD
-2	530213		. Bolt, Connecting Rod, Special .....	2	All
-3	24804		. Nut, Slotted .....	2	All
-4	639292		Pin, Cotter .....	8	All

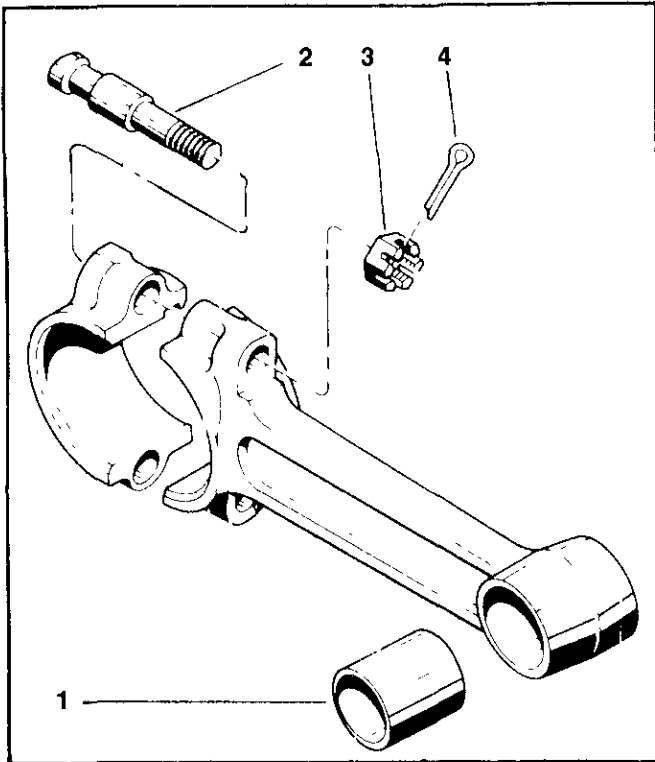

FIGURE 6. CONNECTING ROD ASSEMBLY

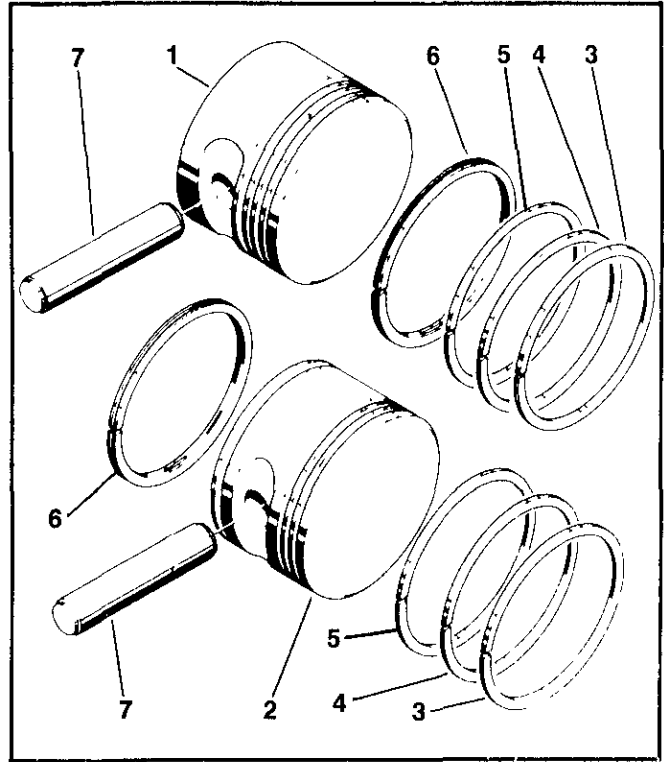

FIGURE 7. PISTON ASSEMBLY

FIG. INDEX	PART NUMBER	1 2 3 4 5	DESCRIPTION	QTY.	CODE
7-1	40327	†	Piston, 6:3:1 Compression Ratio .....	4	AB
-2	530348	†	Piston, 7:0:1 Compression Ratio .....	4	CD
-3	638109	†	Ring, Top Compression .....	4	All
-3	640296	⊙	Ring, Top Compression .....	Opt.	All
-4	638110	†	Ring, Second Groove .....	4	All
-4	640296	⊙	Ring, Second Groove .....	Opt.	All
-5	638110	†	Ring, Third Groove .....	4	All
-5	640297	⊙	Ring, Third Groove .....	Opt.	All
-6	638111	†	Ring, Fourth Groove .....	4	All
-6	640298	⊙	Ring, Fourth Groove .....	Opt.	All
-7	530830		Pin & Plug Assembly, Piston Pin .....	4	All

NOTE:

⊙ These rings are for use with chrome plated cylinders.

FOR COMPLETE RING SETS, SEE SECTION IV.

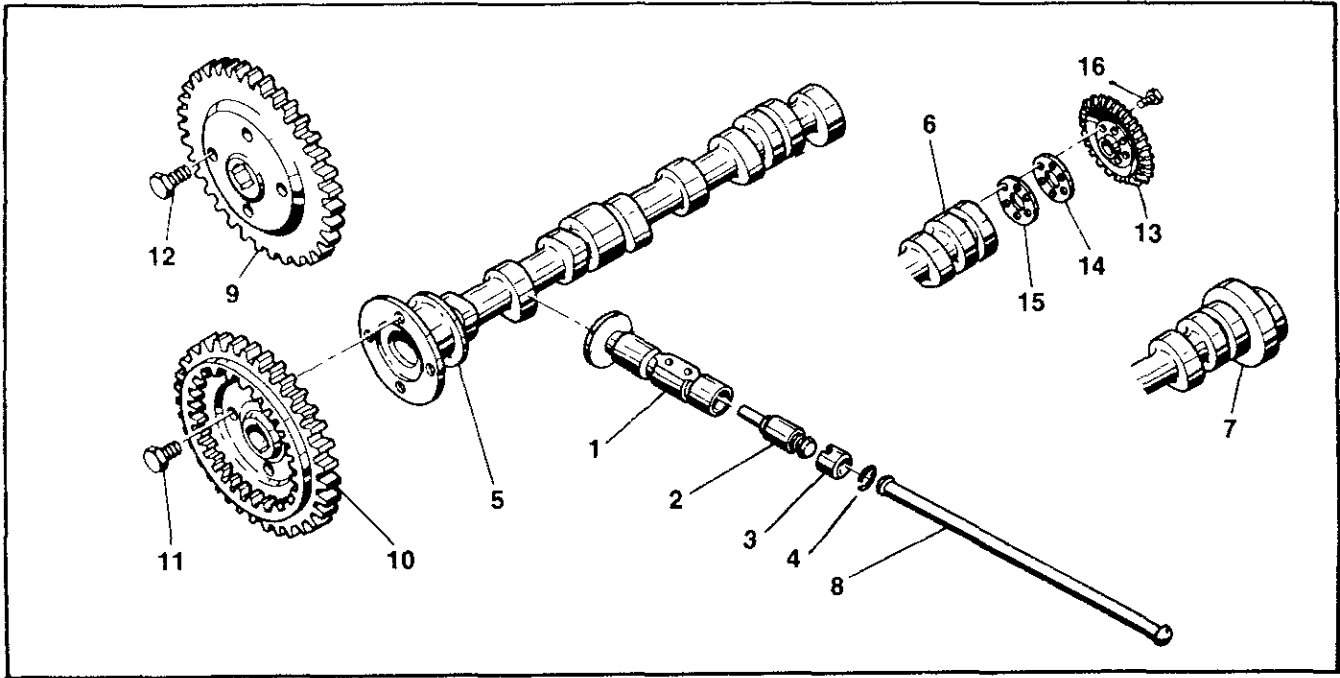

FIGURE 8. CAMSHAFT ASSEMBLY, LIFTERS AND PUSHRODS

FIG. INDEX	PART NUMBER	1 2 3 4 5	DESCRIPTION	QTY.	CODE
8-	A21599		Lifter Assy., Hydraulic Vlv. (used with 40584 Cam)	8	AB
	530872	⊙	Lifter Assy., Hydraulic Vlv. (used with 530788 Cam)	8	Opt.
	637270		Lifter Assy., Hydraulic Vlv. (used with 531076, 631146 or 626608 (Camshaft) .....	8	CD
-1	21608	.	Body, Hydraulic Valve Lifter (part of A21599) ..	1	AB
-1	530851	.	Body, Hydraulic Valve Lifter (part of 637270) ...	1	CD
-1	530873	⊙	Body, Hydraulic Valve Lifter (part of 530872) ...	1	Opt.
-2	637269	.	Unit, Valve Lifter, Hydraulic .....	1	All
-3	637268	.	Socket, Pushrod .....	1	All
-4	530940	.	Ring, Snap .....	1	All
-5	40584	† ②	Camshaft, Cast Iron .....	1	AB
-5	531076	† ③	Camshaft, Forged Steel .....	1	C
-6	531146	†	Camshaft, Forged Steel .....	1	C
-7	626608	†	Camshaft, Forged Steel .....	1	D
-8	537870	†	Pushrod Tube Assembly .....	8	All
-9	3506	④	Gear, Camshaft .....	1	AC
-10	530535		Gear, Camshaft .....	1	All
ATTACHING PARTS					
-11	22534		Screw, Hex Drilled Head .....	4	All
-12	21346	④	Screw, Hex Drilled Head .....	4	AC
* * * *					
-13	3660		Gear, Vacuum Pump Drive .....	1	D
-14	22030		Shim, Vacuum Pump Drive 0.002 Thick .....	AR	C
-15	22031		Shim, Vacuum Pump Drive 0.005 Thick .....	AR	CD
-16	MS9088-08		Screw, Drilled Head .....	6	C
-16	AN502-10-8		Screw, Drilled Head .....	6	D

NOTE:

- ⊙ No longer available
- ② For side fuel pump or none
- ③ 24° overlap (side fuel pump or none)
- ④ All -8, -8F Models

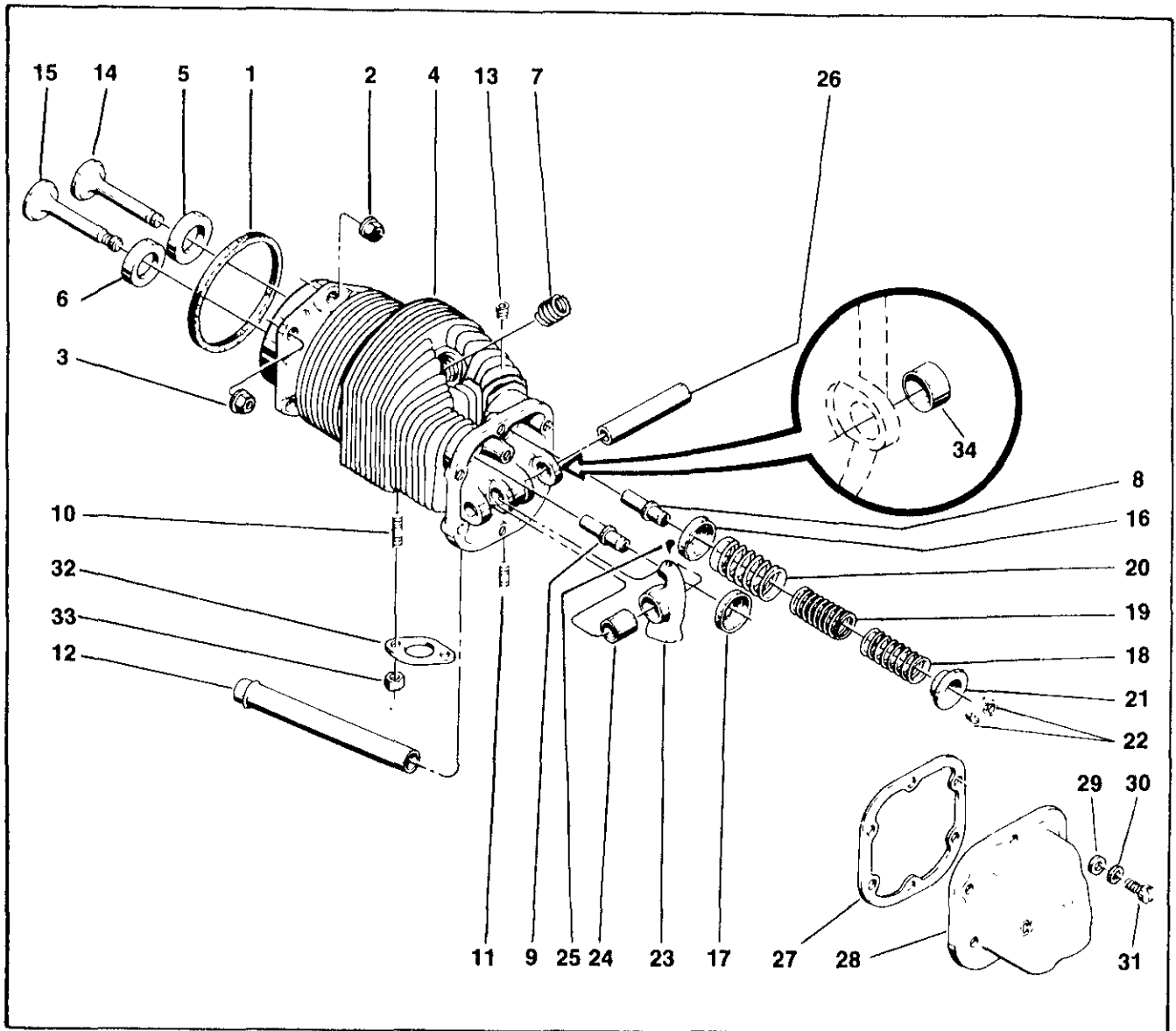

FIGURE 9. CYLINDER ASSEMBLY

FIG. INDEX	PART NUMBER	1 2 3 4 5	DESCRIPTION	QTY.	CODE
9-1	21477	\$	Packing, Cylinder Base .....	4	All
	641917A2		Cylinder & Valve Assembly .....	4	All
	641916A1	①	Cylinder & Valve Assembly .....	4	All
	641917CP-A2	②	Cylinder & Valve Assembly .....	Opt.	All
ATTACHING PARTS					
-2	531003		Nut, Flanged Hex, 3/8 Inch .....	8	All
-3	531001		Nut, Flanged Hex, 7/16 Inch .....	16	All
* * * * *					
-4	641917		Cylinder & Head Assembly .....	1	All
-4	641916	①	Cylinder & Head Assembly .....	1	All
-4	641917CP	②	Cylinder & Valve Assembly .....	Opt.	All
-5	641793	† ③	Insert, Intake Valve Seat .....	1	All
-6	3923	†	Insert, Exhaust Valve Seat .....	1	All

FIG. INDEX	PART NUMBER	1 2 3 4 5	DESCRIPTION	QTY.	CODE
-7	520112		Insert, 18mm Spark Plug Helical Coil .....	2	All
-8	24024	†	Guide, Intake Valve .....	1	All
-9	24047	† ①	Guide, Exhaust Valve .....	1	All
-9	628309	† ②	Guide, Exhaust Valve .....	1	All
-10	402151	†	Stud, Exhaust Flange .....	2	All
-11	401870	†	Stud, Intake Elbow Pad .....	2	All
-12	21284		Housing, Push Rod .....	2	All
-13	629518-1H	\$	Plug .....	1	All
-14	641792	③	Valve, Intake .....	1	All
-15	629404	①	Valve, Exhaust .....	1	All
-15	631639	④	Valve, Exhaust .....	1	All
-16	24026		Retainer, Intake Valve Spring .....	1	All
-17	24044		Retainer, Exhaust Valve Spring .....	1	All
-18	24031		Spring, Inner Valve .....	2	All
-19	24029		Spring, Intermediate Valve .....	2	All
-20	625958		Spring, Outer Valve .....	2	All
-21	24027		Seat, Valve Spring .....	2	All
-22	21361		Lock, Valve Spring Seat .....	4	All
-23	639615		Rocker Arm Assembly, Exhaust .....	1	All
-23	639614		Rocker Arm Assembly, Intake .....	1	All
-24	24122		Bushing, Valve Rocker Arm .....	1	All
-25	21007		Screw, Drive 1/8 Inch .....	1	All
-26	21153	†	Shaft, Valve Rocker .....	1	All
-27	530162	\$	Gasket, Rocker Cover .....	1	All
-28	40762		Cover, Valve Rocker .....	1	All
ATTACHING PARTS					
-29	534471		Washer, Plain 17/64 Inch .....	6	All
-30	MS35337-44		Washer, Lock .....	6	All
-31	535091-62		Screw, Drilled Head .....	6	All
* * * * *					
-32	21493	\$	Gasket, Exhaust Flange, Copper Asbestos .....	4	All
-32	627429		Gasket, Exhaust Flange .....	Opt.	All
-33	22022		Nut, Plain, 5/16 Inch .....	8	All
-34	22949	† ⑤	Bushing, Rocker Shaft Boss .....	AR	All

NOTES.

- ① These parts are contained within the 641916A1 Cylinder Assembly, and are not compatible with the 641917A2. The 641916A1 Cylinder Assembly is no longer available. Use 629404 valve with 24047 guide only.
- ② Chrome Plate.
- ③ Cylinder's A50222 and 639702 used a 45° intake valve and seat and will not accommodate the 30° 641792 valve. Modify per Service Bulletin M76-8.
- ④ Use 631639 valve with 628309 guide only.
- ⑤ Bushing supplied for repair of worn bosses not installed in new engines and installed in this location if cylinder head is tapped with 1/8 Inch NPT hole.

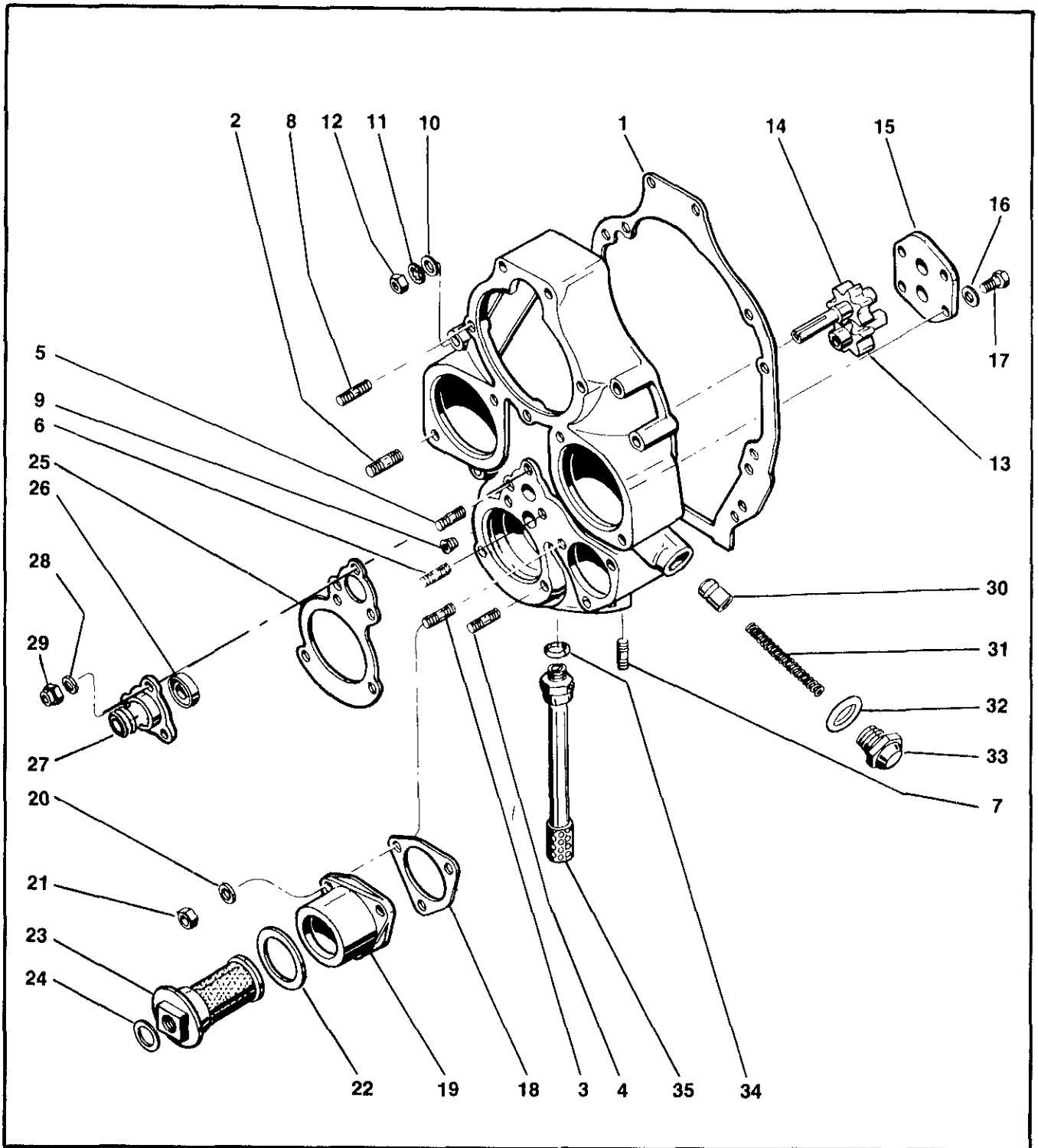

FIGURE 10. CRANKCASE COVER ASSEMBLY

FIG. INDEX	PART NUMBER	1 2 3 4 5	DESCRIPTION	QTY.	CODE
10-1	5484		Gasket, Crankcase Cover .....	1	All
	627307A10	①	Cover Assembly, Crankcase .....	1	ABC
	627307A10	②	Cover Assembly, Crankcase .....	1	CD
-2	401975	†	Stud, Magneto Pad, 5/16 x 1-19/16 Inch Long ..	4	All
-2	402131	†	Stud, Magneto Pad, 5/16 x 1-1/2 Inch Long ....	4	D
-3	401801	†	Stud, 1/4 x 1-3/16 Inch Long .....	1	All
-4	402044	†	Stud, 5/16 x 1-3/8 Inch Long .....	2	All
-5	401801	†	Stud, 1/4 x 1-3/16 Inch Long .....	2	All
-6	401804	†	Stud, 1/4 x 1-1/16 Inch Long .....	1	All
-7	401804	†	Stud, 1/4 x 1-1/16 Inch Long .....	3	All
-8	401971	†	Stud, 5/16 x 1-5/8 Inch Long .....	3	All
-9	2025		Plug, Pipe, 3/8 Inch .....	1	D
			ATTACHING PARTS		
-10	2473		Washer, Plain 5/16 Inch .....	7	All
-11	MS35337-45		Washer, Lock 5/16 Inch .....	7	All
-12	2439		Nut, Plain 5/16 Inch .....	7	All
			* * * *		
-13	22354		Gear, Oil Pump Driven .....	1	All
-14	22355		Gear, Oil Pump Driven .....	1	All
-15	23410		Cover, Oil Pump .....	1	All
			ATTACHING PARTS		
-16	20522		Washer, 1/4 Inch .....	4	All
-17	22537		Screw, Drilled Head, 1/4 x 5/8 Inch Long .....	4	All
			* * * *		
-18	22350	\$	Gasket, Oil Screen Housing .....	1	All
-19	35020		Housing, Oil Screen .....	1	All
			ATTACHING PARTS		
-20	20522		Washer, Plain 1/4 Inch .....	3	All
-21	2437		Nut, Plain 1/4 Inch .....	3	All
			* * * *		
-22	AN900-28	\$	Gasket, Copper Asbestos, 1-3/4 Inch .....	1	All
-23	A3568		Screen Assembly, Oil .....	1	All
-24	AN900-10	\$	Gasket, Copper Asbestos, 5/8 Inch .....	1	All
-25	35019	\$	Gasket, Tach Drive Hsg & Generator .....	1	All
-26	642714	\$	Seal, Tach Drive, Oil .....	1	All
-27	35018		Housing, Tach Drive .....	1	All
			ATTACHING PARTS		
-28	20522		Washer, Plain, 1/4 Inch .....	3	All
-29	22661		Nut, Elastic Stop 1/4 Inch .....	3	All
			* * * *		
-30	21114		Plunger, Oil Pressure Relief Valve .....	1	All
-31	637083		Spring, Oil Pressure Relief Valve .....	1	All
-32	AN900-14	\$	Gasket, Copper Asbestos, 7/8 Inch .....	1	All
-33	21113		Cap, Oil Pressure Relief Valve .....	1	All
-34	AN900-10	\$	Gasket, Copper Asbestos, 5/8 Inch .....	1	All
-35	A22301		Tube Assembly, Oil Suction .....	1	All

NOTES:

- ① Not used on -8 Models
- ② Used on C90-16F.

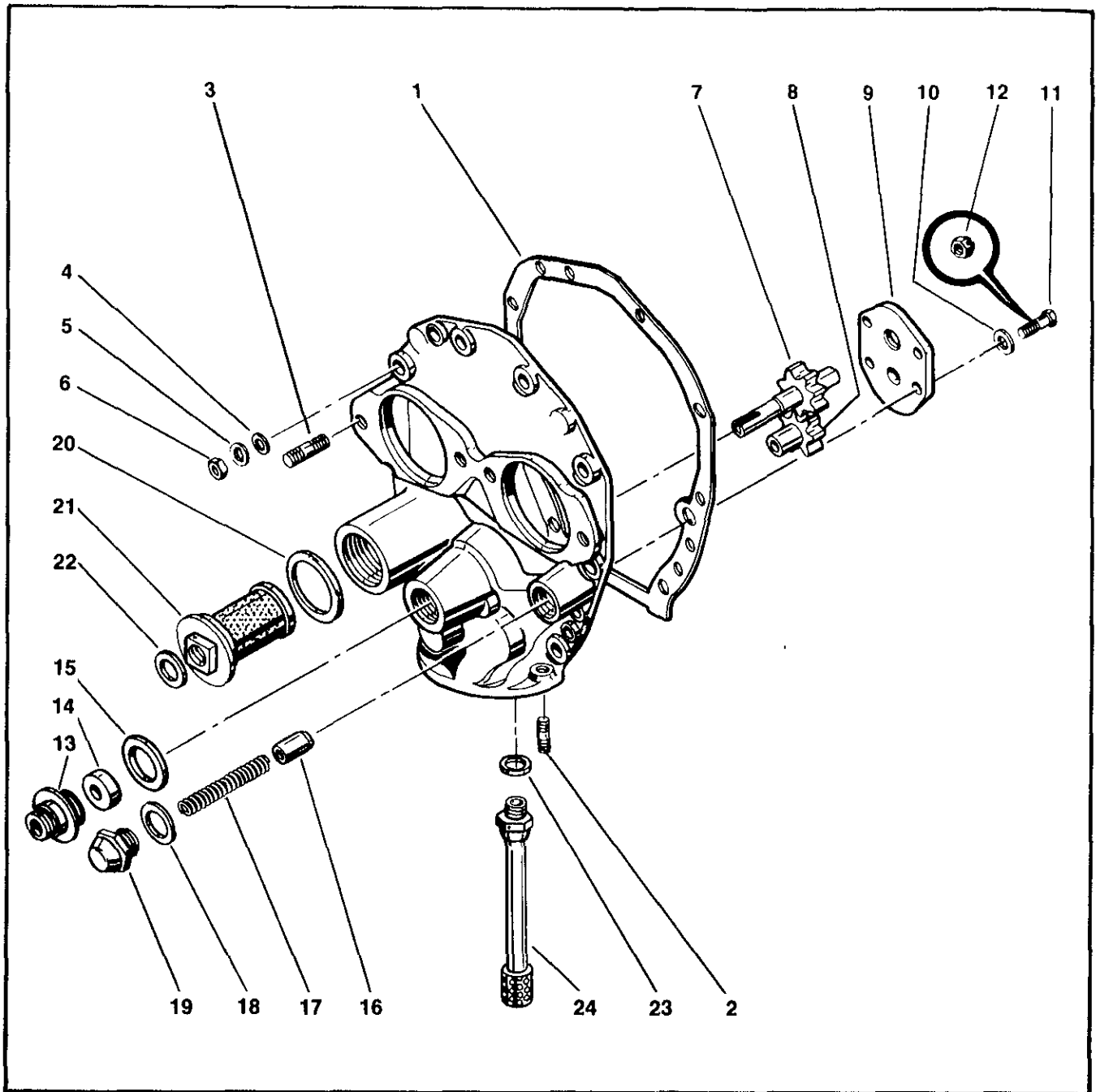

FIGURE 11. CRANKCASE COVER ASSEMBLY



FIG. INDEX	PART NUMBER	1 2 3 4 5	DESCRIPTION	QTY.	CODE
11-1	4577		\$ Gasket, Crankcase Cover .....	1	ABC
	A4587		① Cover Assembly, Crankcase .....	1	ABC
-2	401804		† Stud, 1/4 x 1-1/16 Inch Long .....	3	ABC
-3	401824		† Stud, 5/16 x 1-1/2 Inch Long .....	4	ABC
			ATTACHING PARTS		
-4	2473		Washer, Plain 5/16 Inch .....	10	ABC
-5	MS35338-45		Washer, Lock .....	10	ABC
-6	2439		Nut, Plain 5/16 Inch .....	10	ABC
			* * * *		
-7	3562		Gear and Drive Shaft, Oil Pump .....	1	ABC
-8	21343		Gear and Shaft, Oil Pump Driven .....	1	ABC
-9	21160		Cover, Oil Pump .....	1	ABC
			* * * *		
-10	20522		Washer, Plain 1/4 Inch .....	4	ABC
-11	22537		Screw, Drilled Head, 1/4 x 5/8 Inch Long .....	4	ABC
-12	2456		② Nut, Hex Castle 1/4 Inch .....	4	ABC
			* * * *		
-13	21208A2		Housing, Tach Drive .....	1	ABC
-14	642714		\$ Seal, Tach Drive, Oil .....	1	ABC
-15	632085		\$ Gasket, Copper Asbestos, 1-3/8 Inch .....	1	ABC
-16	21114		Plunger, Oil Pressure Relief Valve .....	1	ABC
-17	637083		Spring, Oil Pressure Relief Valve .....	1	ABC
-18	AN900-14		\$ Gasket, Copper Asbestos, 7/8 Inch .....	1	ABC
-19	21113		Cap, Oil Pressure Relief Valve .....	1	ABC
-20	AN900-28		\$ Gasket, Copper, Asbestos, 1-3/4 Inch .....	1	ABC
-21	A3568		Screen Assembly, Oil .....	1	ABC
-22	AN900-10		\$ Gasket, Copper Asbestos, Oil Screen Housing ...	1	ABC
-23	AN900-10		\$ Gasket, Copper Asbestos, Oil Screen Housing ...	1	ABC
-24	A22301		Tube Assembly, Oil Pump Suction .....	1	ABC

NOTES:

① Used on -8 Models only.

② For use only when stud, Part No. 21393, is in serviceable condition.

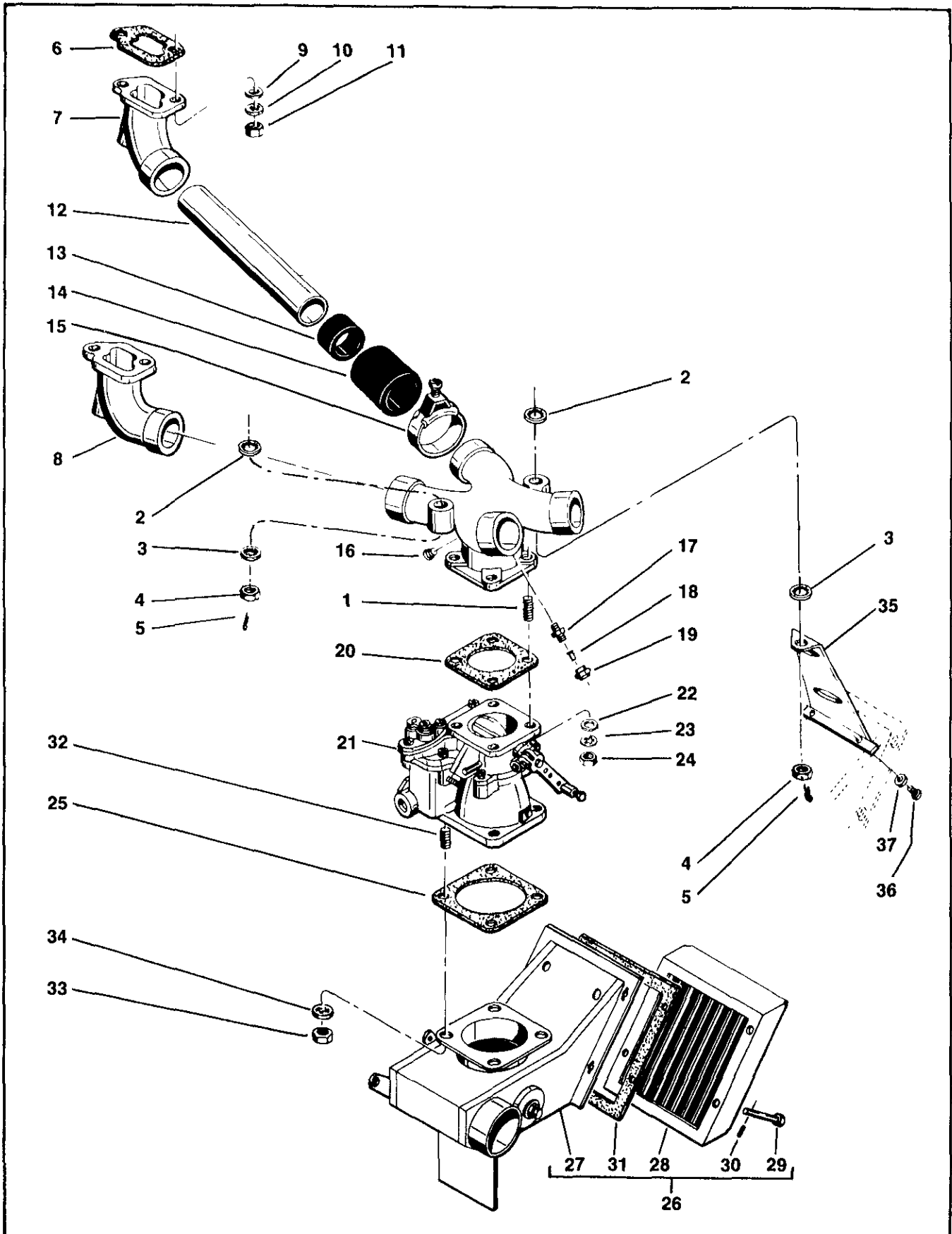

FIGURE 12. CARBURETOR INDUCTION SYSTEM

FIG. INDEX	PART NUMBER	1 2 3 4 5	DESCRIPTION	QTY.	CODE
12-	35145A1		Manifold Assembly, Intake .....	1	All
-1	401893	†	Stud, 1/4 x 1-1/4 Inch Long .....	4	All
			ATTACHING PARTS		
-2	538556		Lock-O-Seal .....	2	All
-3	538556		Lock-O-Seal .....	2	All
-4	2557		Nut, Special 3/8 Inch .....	2	ABC
-4	2458		Nut, Castle 3/8 Inch .....	2	D
-5	MS24665-155		Cotter, Pin .....	2	D
			* * * * *		
-6	22250	\$	Gasket, Intake Elbow .....	4	All
-7	40246		Elbow, Cylinder 1 and 4, Intake .....	2	All
-8	40247		Elbow, Cylinder 2 and 3, Intake .....	2	All
			ATTACHING PARTS		
-9	20522		Washer, Plain 1/4 Inch .....	8	All
-10	MS35337-44		Washer, Lock .....	8	D
-11	2437		Nut, Plain 1/4 Inch .....	8	All
			* * * * *		
-12	21182		Pipe, Intake .....	4	All
-13	21185	\$	Connector, Hose, 1-1/2 Inch .....	8	All
-14	22800	\$	Connector, Hose, 1-3/4 Inch .....	8	All
-15	36151N		Clamp, Hose .....	16	All
-16	2024		Plug, Socket Head .....	1	All
-17	AN4022-1		Jet, Primer .....	1	All
-18	20720		Cone, 1/8 Inch Tube .....	1	All
-19	AN805-2		Nut, Tube Union, 1/8 Inch .....	1	All
-20	21051	\$	Gasket, Carburetor to Manifold .....	1	All
-21	627366		Carburetor, Marvel-Schebler 84240 .....	1	AB
-21	627367		Carburetor, Marvel-Schebler MA-3SPA .....	1	C
-21	633028	①	Carburetor, Marvel-Schebler MA3SPA .....	1	D
			ATTACHING PARTS		
-22	20522		Washer, 1/4 Inch .....	4	All
-23	MS35337-44		Washer, Lock 7/16 Inch .....	4	All
-24	2437		Nut, Plain 1/4 Inch .....	4	All
			* * * * *		
-25	21323	\$	Gasket, Air Intake .....	1	All
-26	A40522	②	Intake Assembly, Carburetor, Air .....	1	All
-26	A40793	③	Intake Assembly, Carburetor, Air .....	1	CD
-27	A50256		Housing Assy., Carburetor Air (part of A40522) .....	1	AC
-27	A50495		Housing Assy., Carburetor Air (part of A40793) .....	1	BCD
	627361		Filter Assembly, Carburetor Air .....	1	All
-28	40599		Filter Carburetor Air Intake .....	1	All
-29	24306		Stud, Filter Camlock .....	4	All
-30	24308		Pin, Camlock Stud Cross .....	4	All
-31	35923	\$	Gasket, Air Filter to Housing .....	1	All
			ATTACHING PARTS		
-32	402711	†	Stud, Plain 1/4 x 7/8 Inch Long .....	4	All
-33	2437		Nut Plain, Hex 1/4 - 28 .....	4	All
-34	MS35337-44		Washer, Lock .....	4	All
-35	A35917		Support Assembly, Carburetor Air Intake .....	1	All
-36	AN501A10-5		Screw, Fillister Head .....	2	All
-37	2471		Washer, Plain 7/16 Inch .....	2	All
			* * * * *		

NOTES:

- ① 633028 (IO-4894) same as 627143 except throttle shaft return spring is omitted.
- ② Installed on C90 engines when equipped with Stromberg Carburetors. See Section VI.
- ③ Used on C90 and O-200 series when equipped with Marvel-Schebler carburetors. See Section VI.

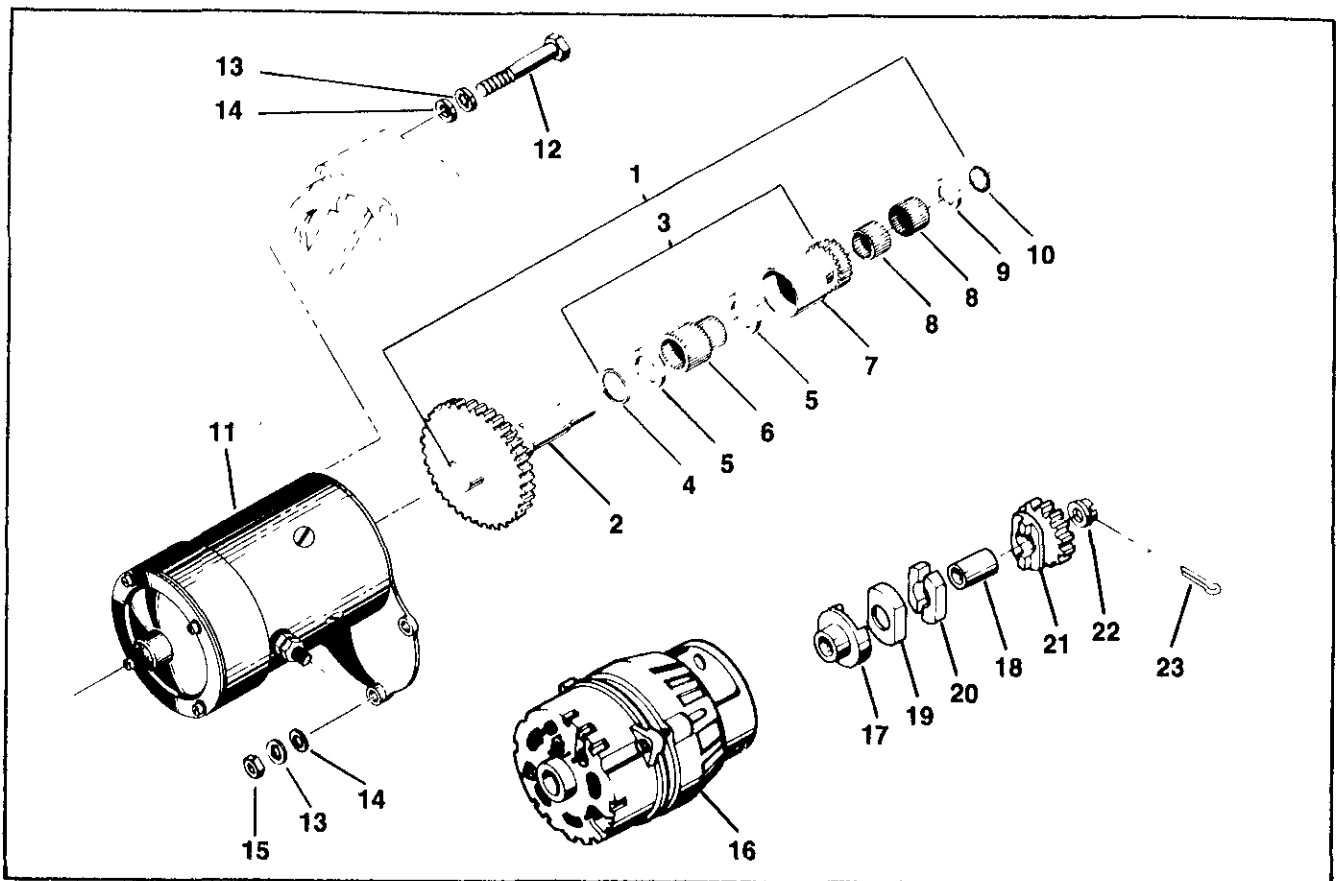

FIGURE 13. STARTER AND GENERATOR

FIG. INDEX	PART NUMBER	1 2 3 4 5	DESCRIPTION	QTY.	CODE
13-1	641500	①	Gear and Clutch Assembly .....	1	D
-2	641497	.	Gear and Shaft Assembly .....	1	D
-3	641499	.	Gear and Sprag Pack Assembly .....	1	D
-4	639970	..	Retainer .....	1	D
-5	640033	..	Washer .....	2	D
-6	639789	..	Sprag Pack .....	1	D
-7	641498	..	Gear and Sprag Housing .....	1	D
-8	639788	.	Needle Bearing .....	2	D
-9	640036	.	Washer .....	1	D
-10	640174	.	Ring, Retaining .....	1	D
-11	634464	①	Starter .....	1	D
-12	630966-3.31		Bolt .....	2	D
-13	MS35337-45		Washer, Lock 5/16 Inch .....	Ref.	D
-14	2473		Washer, Plain 5/16 Inch .....	Ref.	D
-15	2439		Nut, 5/16 Inch .....	Ref.	D
-16	633661	①	Alternator, 60 Amp 28 Volt .....	1	D
-17	530406	.	Hub .....	1	D
-18	530407	.	Sleeve .....	1	D
-19	352030	.	Retainer .....	1	D
-20	632050	.	Bushing .....	2	D
-21	531325	.	Gear .....	1	D
-22	530412	.	Nut, Castle .....	1	D
-23	639292	.	Cotter Pin .....	1	D
	639297		Kit, Starter Clutch Spacer .....	1	D
	639298		Tool Kit, Starter Clutch Spacer .....	1	D

NOTE:

① Used on key start engines spec. 48 and above.

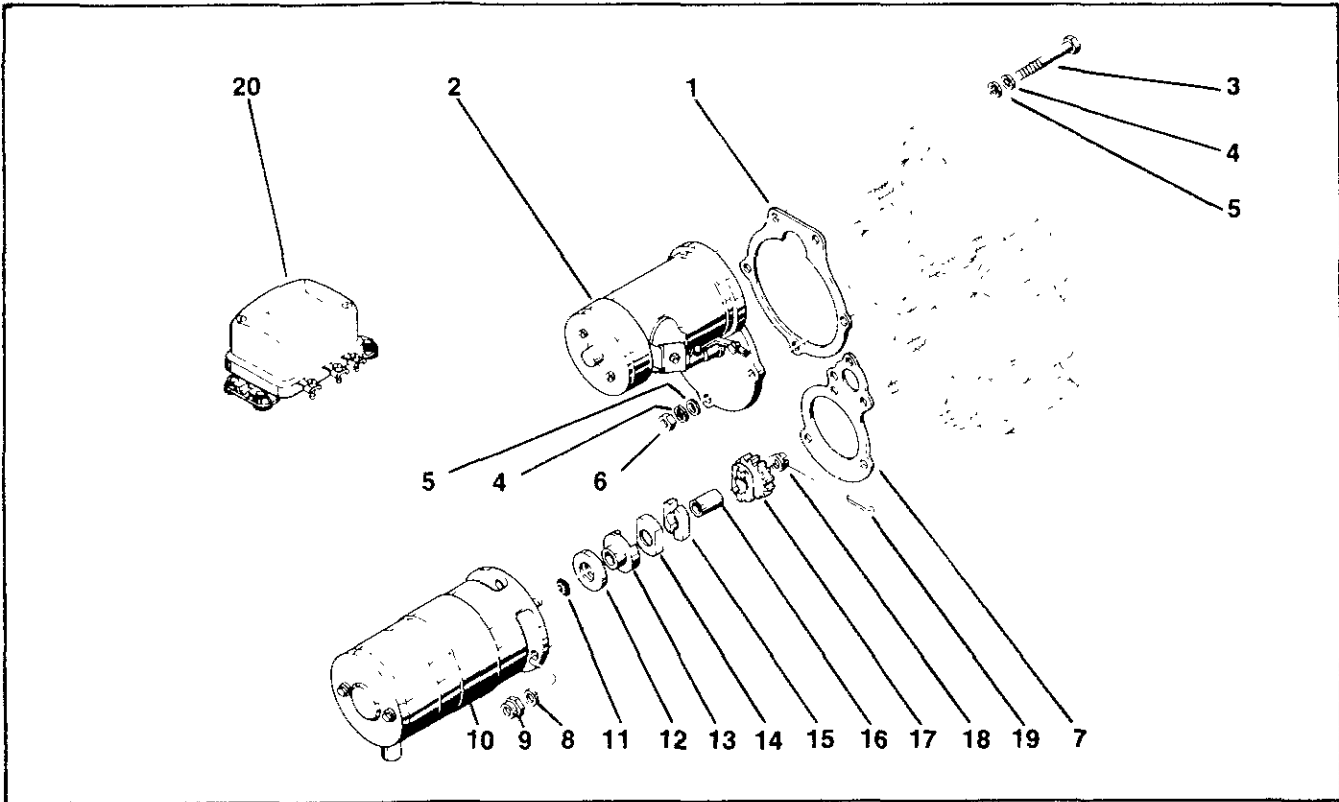

FIGURE 14. STARTER, GENERATOR, VOLTAGE REGULATOR

FIG. INDEX	PART NUMBER	1 2 3 4 5	DESCRIPTION	QTY.	CODE
14-1	352179	\$	Gasket, Starter Pad .....	1	All
-2	50309	⊙	Starter, Complete, Delco-Remy No. 119656 .....	1	All
			ATTACHING PARTS		
-3	538999		Bolt, Hex Drilled Head .....	2	All
-4	MS35337-45		Washer, Lock 5/16 Inch .....	5	All
-5	2473		Washer, Plain 5/16 Inch .....	5	All
-6	2439		Nut, Plain 5/16 Inch .....	3	All
-7	35019	\$	Gasket .....	Ref.	All
	534208	⊙	Generator Assembly Complete (12V, 20 AMP) ...	1	All
			ATTACHING PARTS		
-8	MS35337-45		Washer, Lock 5/16 Inch .....	3	All
-9	2439		Nut, Plain 5/16 Inch .....	3	All
			* * * *		
-10	534111	.	Generator, 20 Amp, 12 Volt .....	1	All
-11	AN123864	\$	Seal, O-Ring, 7/16 Inch .....	1	All
-12	352068	\$	Seal, Oil .....	1	All
-13	530406	.	Hub, Generator Coupling .....	1	All
-14	352030	.	Retainer, Coupling Disc. ....	1	All
-15	626543	.	Bushing Generator Drive Coupling .....	2	All
-16	530407	.	Sleeve Generator Drive Coupling .....	1	All
-17	531325	.	Gear, Generator Drive .....	1	All
-18	530412	.	Nut, Shouldered, Slotted 5/16 Inch .....	1	All
-19	MS24665-132	.	Pin, Cotter, 1/16 Inch .....	1	All
-20	* * *	⊙	Regulator, Voltage .....	1	All

NOTES:

- ⊙ Used on spec. 1 thru 38.
- ⊙ See Section VI for specific application.

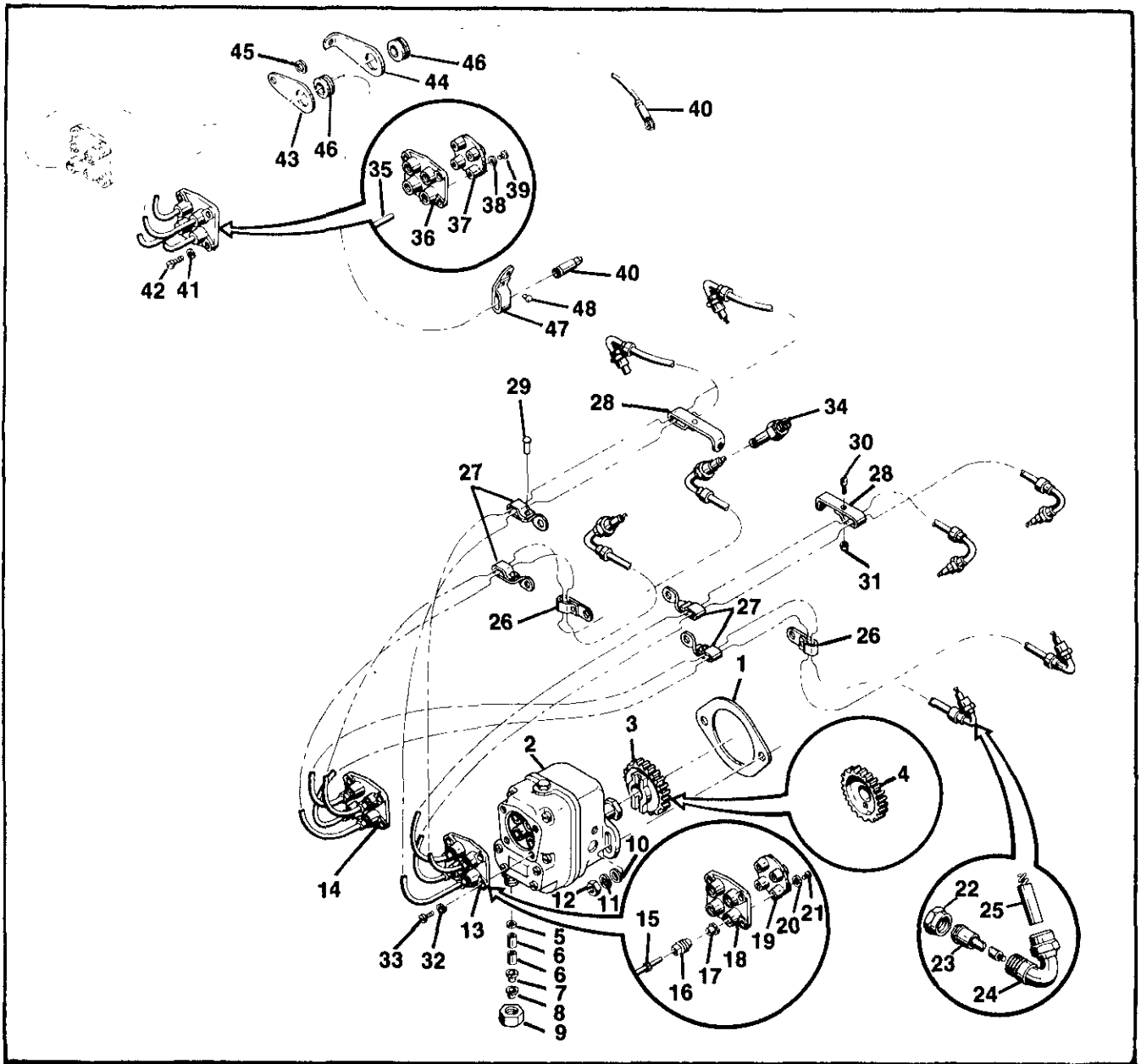

FIGURE 15. BENDIX IGNITION SYSTEM (S4LN-21, S4RN-21)

FIG. INDEX	PART NUMBER	1 2 3 4 5	DESCRIPTION	QTY.	CODE
15-1	535324	\$	Gasket, Magneto Flange .....	2	All
-2	50483		Magneto, Bendix S4LN-21 (Impulse Counterclockwise) .....	2	All
-2	530209	Ⓢ	Magneto, Bendix S4RN-21 (Impulse Clockwise) .	2	C
-3	36066		Gear, Magneto Drive .....	1	All
-4	36067	Ⓢ	Gear Magneto Drive .....	1	C
	A25277		Kit, Magneto Ground Terminal .....	2	All
-5	25314	.	Washer, Plain .....	1	All
-6	25315	.	Sleeve, Insulating .....	2	All
-7	25316	.	Ferrule, Groundwire Inner .....	1	All
-8	25317	.	Ferrule, Groundwire Outer .....	1	All
-9	25318	.	Nut, Hex Coupling .....	1	All

FIG. INDEX	PART NUMBER	1 2 3 4 5	DESCRIPTION	QTY.	CODE
ATTACHING PARTS					
-10	401506		Washer, Plain .....	4	All
-11	MS35337-45		Washer, Lock 5/16 Inch .....	4	All
-12	2439		Nut, Plain 5/16 Inch .....	4	All
			* * * *		
	530061A2		Cable Assy., Complete Radio Shielded .....	1	D
	530375A1	⊙	Cable Assembly, Complete .....	1	C
-13	530061		Cable and Plate Assy., Upper Ignition .....	1	D
-13	530375	⊙	Cable and Plate Assy., Upper Ignition .....	1	C
-14	530062		Cable and Plate Assy., Lower Ignition .....	1	D
-14	530376	⊙	Cable and Plate Assy., Lower Ignition .....	1	C
-15	25301		Cable, Ignition Shielded .....	AR	All
-16	25302		Nut, Coupling .....	4	All
-17	20087		Ferrule, Ignition Cable .....	4	All
-18	25305		Plate, 4 Cylinder Shielded Outlet .....	1	All
-19	40794		Grommet, 4 Cylinder Distributor Cable .....	1	All
-20	25388		Washer, Plain .....	4	All
-21	25387		Screw, Cable Contact .....	4	All
-22	532148		Nut, Cable-to-Elbow .....	4	All
-23	532149		Ferrule, Cable-to-Elbow .....	4	All
-24	532151		Elbow, Spark Plug Lead .....	4	All
-25	628986		Sleeve, Spark Plug Contact .....	4	All
-26	21459		Bracket, Ignition Cable .....	2	All
-27	530059		Bracket, Ignition Cable .....	4	ACD
-28	530886		Bracket, Ignition Cable .....	2	All
-29	21264		Rivet, Round Head Iron, 1/8 (dia.) x 1/4 Inch ..	AR	All
-30	627759		Bolt, Fillister Head No. 6-32 x 5/16 Inch .....	2	ACD
-31	MS21044N06		Nut, Stop .....	2	All
ATTACHING PARTS					
-32	25321		Washer, Lock No. 10 .....	8	All
-33	25320		Screw, Fillister Head .....	8	all
			* * * *		
-34	632503		Plug, Radio Shielded Spark, 18mm .....	8	D
-34	632501		Plug, Radio Unshielded spark, 18mm .....	8	ABC
	530700A1		Cable Assy., Complete Unshielded Ignition .....	1	BC
	627667A1		Cable Assy., Complete Unshielded Ignition .....	1	ABC
-35	21082		Cable, Unshielded Ignition, 19 Strand Copper ..	AR	ABC
-36	25305		Plate, 4 Cylinder Cable Outlet .....	1	ABC
-37	40794		Grommet, 4 Cylinder Distributor Cable .....	1	ABC
-38	25388		Washer, Plain .....	4	ABC
-39	25387		Screw, Cable Contact .....	4	ABC
-40	2306		Terminal, Spark Plug Safety Lock .....	4	ABC
ATTACHING PARTS					
-41	25321		Washer, Lock No. 10 .....	4	ABC
-42	25320		Screw, Fillister Head No. 10-32 x 5/8 Inch .....	4	ABC
			* * * *		
-43	22493		Bracket, Ignition Cable, Rear .....	2	ABC
-44	530886		Bracket, Ignition Cable, Upper Front, Left & Right	2	ABC
-45	20522		Washer, Plain .....	2	ABC
-46	22495		Grommet, Ignition Cable Bracket .....	6	ABC
-47	25145		Bracket, Ignition Cable Lower No. 3 & 4 Cylinder	2	ABC
-48	21264		Rivet, Round Head Iron .....	2	ABC

NOTE:

⊙ Used on -8 only.

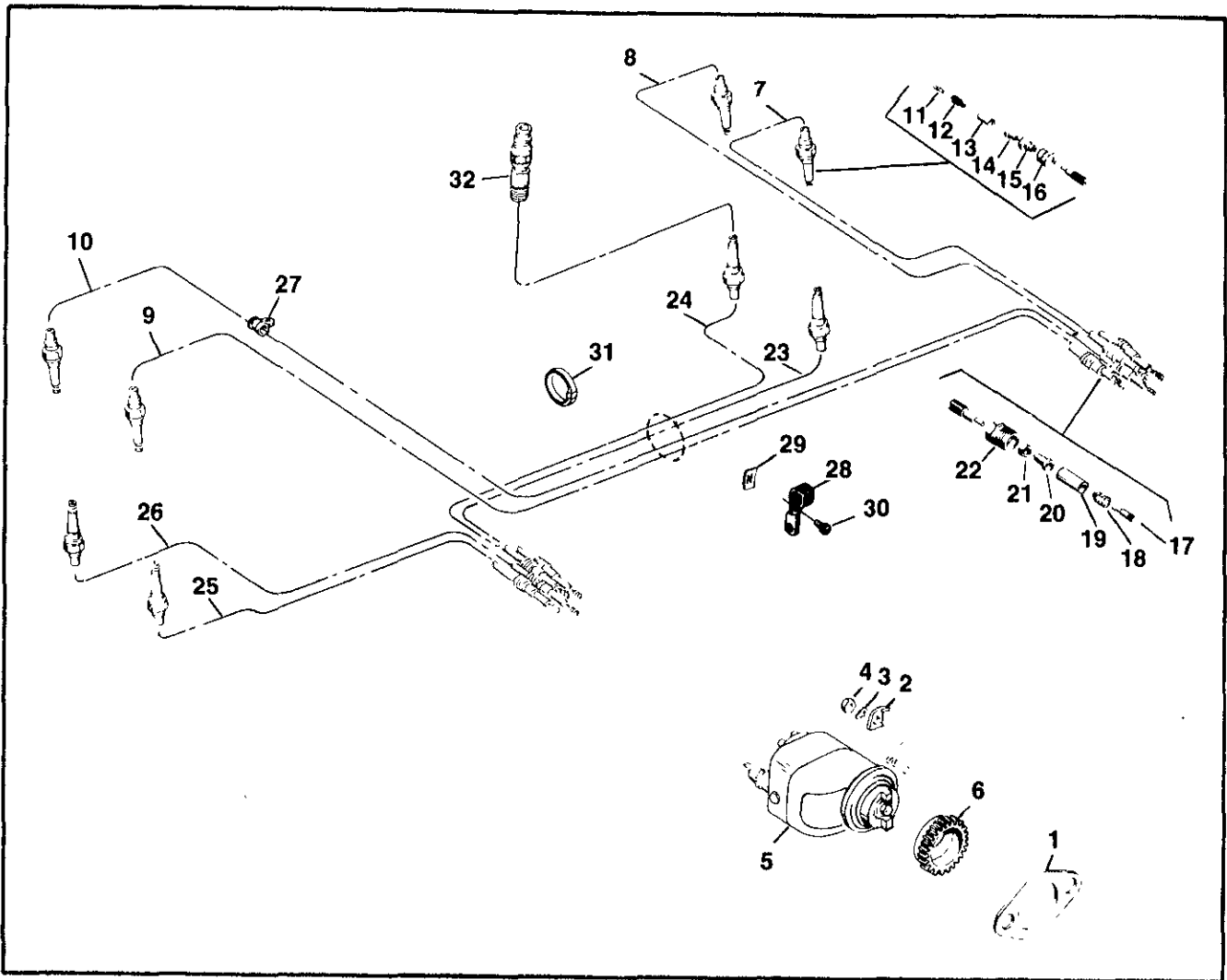

FIGURE 16. SLICK IGNITION SYSTEM (MODEL 447)



FIG. INDEX	PART NUMBER	1 2 3 4 5	DESCRIPTION	QTY.	CODE
16-1	534750	\$	Gasket, Magneto Flange .....	2	D
			ATTACHING PARTS		
-2	642370		Washer, Plain, Mag. Hold .....	4	D
-3	MS35337-45		Washer, Lock 5/16 Inch Long .....	4	D
-4	2439		Nut, Plain Hex 5/16 Inch Long .....	4	D
			* * * *		
-5	633122		Magneto, Slick Type 447 .....	2	D
-6	36066		Gear, Magneto Drive .....	2	D
	633163		Ignition Cable Assembly, Complete .....	1	D
-7	634342	②	Cable Assy., No. 1 Upper, 26-1/2 Inch Long ...	1	D
-8	634342	②	Cable Assy., No. 3 Upper, 29 Inch Long .....	1	D
-9	634342	②	Cable Assy., No. 2 Upper, 33-1/2 Inch Long ...	1	D
-10	634342	②	Cable Assy., No. 4 Upper, 35-1/2 Inch Long ...	1	D
-11	633585	①	Screw, Electrode .....	1	D
-12	633586	①	Spring .....	1	D
-13	634338	①	Sleeve, Insulator .....	1	D
-14	633583	①	Ferrule, Drive .....	1	D
-15	634339	①	Ferrule, Ignition .....	1	D
-16	634337	①	Nut, Spark Plug .....	1	D
-17	633585	①	Screw, Electrode .....	1	D
-18	633586	①	Spring .....	1	D
-19	633584	①	Sleeve .....	1	D
-20	633583	①	Ferrule, Drive .....	1	D
-21	633582	①	Washer, .....	1	D
-22	633581	①	Nut, Magneto End .....	1	D
-23	634342	②	Cable Assy., No. 1 Lower, 42 Inch Long .....	1	D
-24	634342	②	Cable Assy., No. 3 Lower, 42 Inch Long .....	1	D
-25	634342	②	Cable Assy., No. 2 Lower, 40 Inch Long .....	1	D
-26	634342	②	Cable Assy., No. 4 Lower, 40 Inch Long .....	1	D
-27	633925		Clamp .....	4	D
-28	633924		Clamp Assembly .....	2	D
-29	633927		Nut, Tinnerman No. 6 .....	2	D
-30	636687		Screw, No. 6 x 3/8 Inch .....	2	D
-31	633926		Ty-Raps .....	AR	D
-32	632503		Spark Plugs .....	Ref.	D

NOTE:

- ① Index No's 11-22 are applicable to all ignition leads.
- ② Replacement leads are sold in one length less spark plug nut and magneto end hardware, and must be cut to appropriate lengths.

FIG. INDEX	PART NUMBER	1 2 3 4 5	DESCRIPTION	QTY.	CODE
17-	EQ5334		Cooler Equipment, Oil .....	Opt.	ABC
-1	4763		. Adapter, Oil Cooler .....	1	ABC
			ATTACHING PARTS		
-2	22344		. Gasket .....	RF	ABC
-3	2473		. Washer, 5/16 Inch .....	RF	ABC
-4	MS35338-45		. Washer, Lock 5/16 Inch .....	RF	ABC
-5	2439		. Nut, 5/16 Inch .....	RF	ABC
			* * * *		
-6	401753		. Plug, Socket Head, 1/4 Inch NPT .....	2	ABC
-7	2024		. Plug, Socket Head, 1/8 Inch NPT .....	1	ABC
-8	2849		. Ball, By-Pass Valve .....	1	ABC
-9	2848		. Spring, By-Pass Valve .....	1	ABC
-10	AN900-10		. Gasket .....	1	ABC
-11	532432		. Plug, Hex Drilled Head 5/8 - 18 .....	1	ABC
-12	530264		. Cooler, Oil .....	1	ABC
-13	22133		. Gasket, Oil Cooler .....	1	ABC
			ATTACHING PARTS		
-14	2474		. Washer, Plain 3/8 Inch .....	3	ABC
-15	2441		. Nut, Plain Hex, 3/8 Inch .....	3	ABC

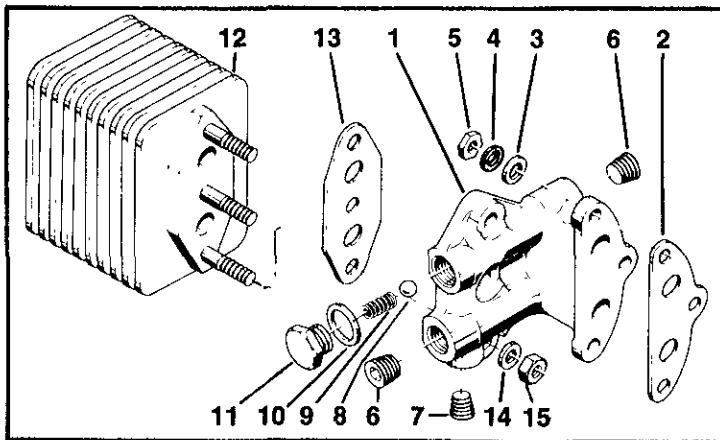

FIGURE 17. OIL COOLER EQUIPMENT

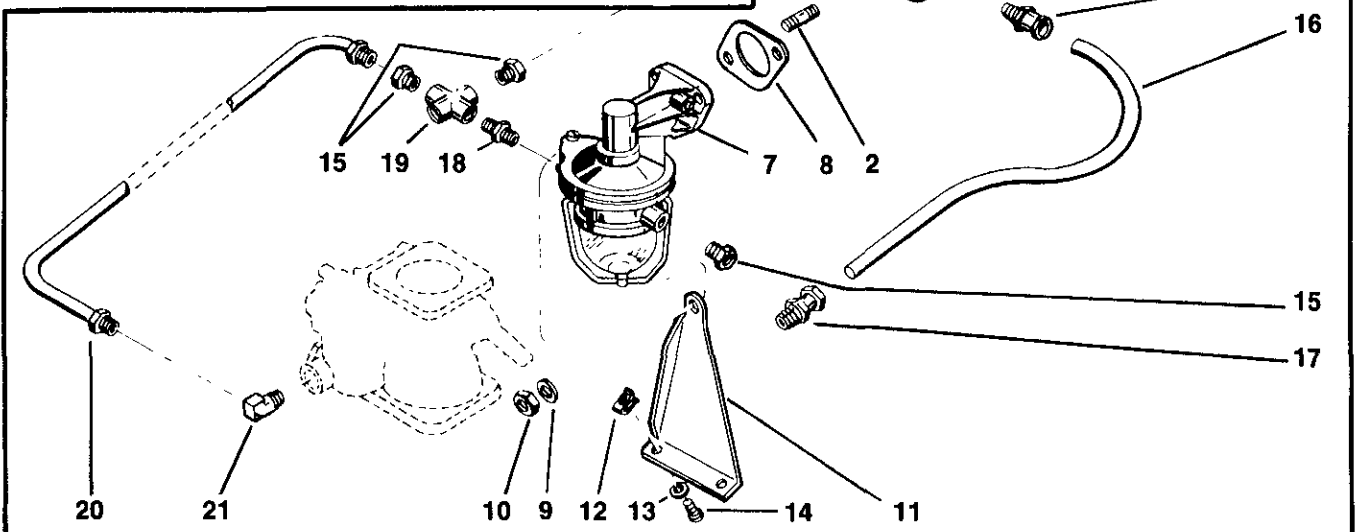
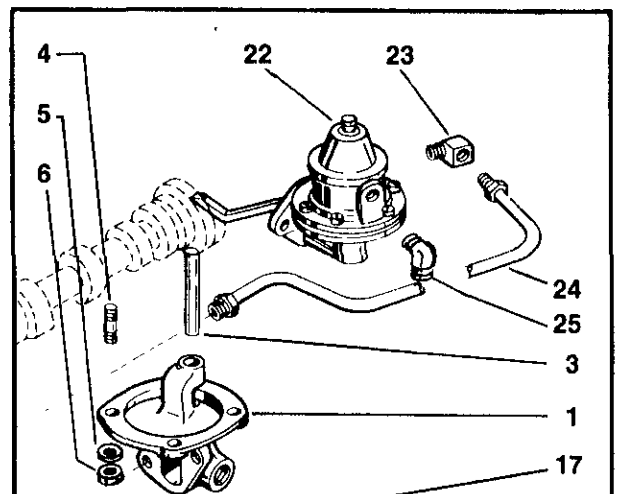
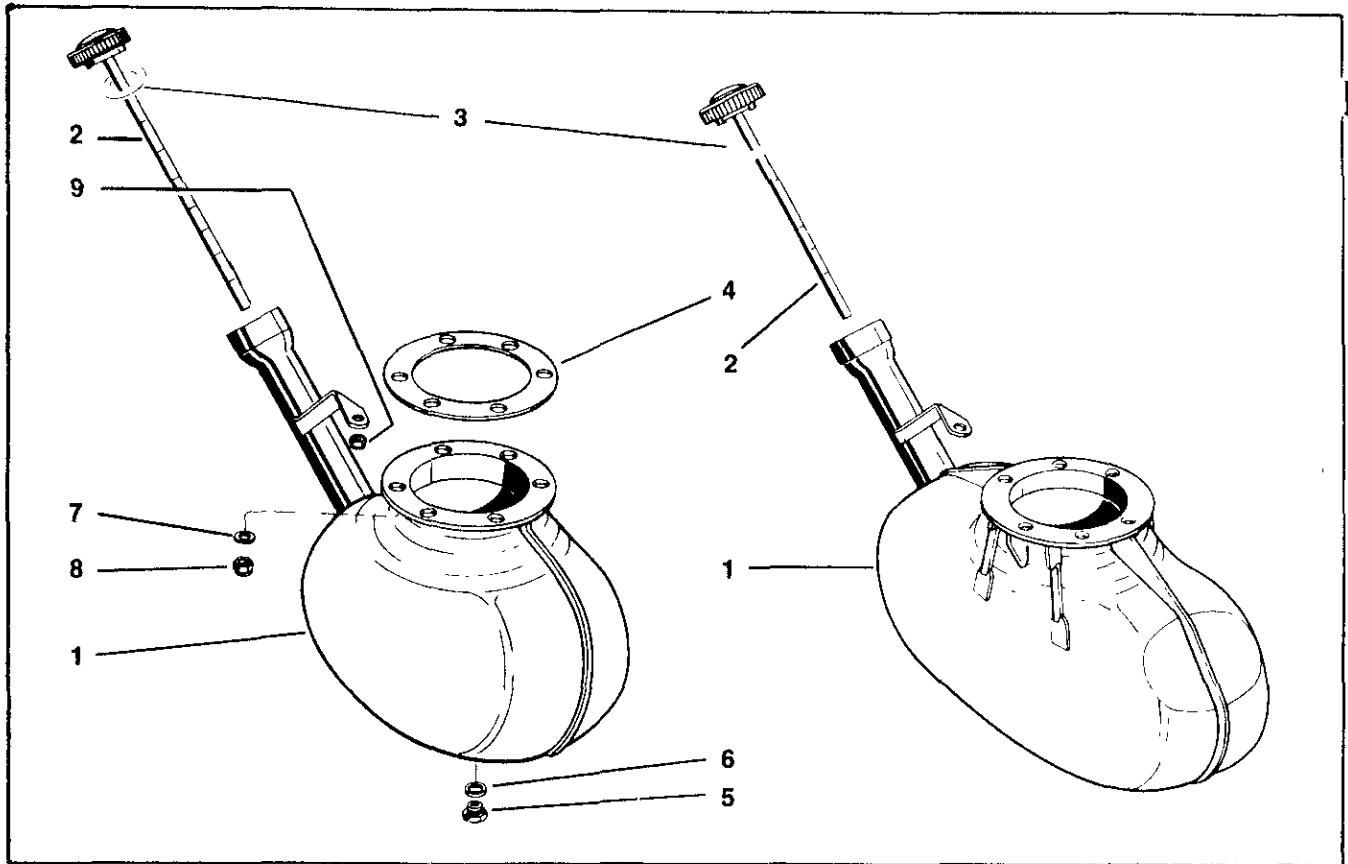

FIGURE 18. FUEL PUMP EQUIPMENT

FIG. INDEX	PART NUMBER	1 2 3 4 5	DESCRIPTION	QTY.	CODE
18-1	50207A1		Adapter Assembly, Lower Pump .....	Opt	B
			ATTACHING PARTS		
-2	402045	†	Stud, 5/16 x 1-1/2 Inch Long .....	2	B
-3	24434		Rod, Push .....	1	B
-4	401805	†	Stud, 1/4 x 1-1/8 Inch, Drilled .....	4	B
-5	20522		Washer, Plain .....	4	B
-6	2458		Nut, Slotted .....	4	B
			* * * * *		
-7	40452		Pump, Lower Fuel .....	1	B
-8	24915		Gasket, Lower Fuel Pump .....	1	B
			ATTACHING PARTS		
-9	2473		Washer, Plain .....	2	B
-10	2471		Washer, Plain .....	2	B
			* * * * *		
-11	36104		Bracket, Air Intake .....	1	B
			ATTACHING PARTS		
-12	23166		Nut, Speed .....	2	B
-13	2471		Washer, Plain .....	2	B
-14	24456		Screw, Fillister Drilled, Head, No 10-32 x 3/8 Inch .....	2	B
			* * * * *		
-15	24947		Connector, 1/8 NPT x 5/16 Tube .....	4	B
-16	35798		Tube, Oil Drain .....	1	B
-17	A24197		Connector, Drain Tube .....	2	B
-18	AN911-1		Nipple, Lower Pump Outlet, 1/8 NPT .....	1	B
-19	AN918-1D		Cross, 1/8 NPT .....	1	B
-20	A24706		Tube Assembly, Pump to Carburetor .....	1	B
-21	24946		Elbow, Pump Outlet, 1/8 NPT x 5/16 Tube .....	1	ABC
-22	40585		Pump, Side Mounted, Fuel .....	Opt.	All
-22	631391	①	Pump, Side Mounted, Fuel .....	Opt.	All
-23	24945		Elbow, Pump Outlet, 1/8 NPT x 5/16 Tube .....	1	ABC
-24	A50329		Tube Assembly, Side Pump to Cross .....	1	B
	A50330		Tube Assembly, Side Pump to Carburetor .....	1	ABC
	627728	②	Tube Assembly, Pump to Carburetor .....	1	C
-25	21619		Elbow, Side Pump Inlet, 1/8 NPT x 1/4 Tube .....	1	ABC

NOTES:

- ① For Champion Lancer use Fuel Pump No. 631391.
- ② Install on engines using Marvel-Schebler Carburetors, Part No. 10-4252.



**FIGURE 19. OIL SUMP ASSEMBLIES**

FIG. INDEX	PART NUMBER	1	2	3	4	5	DESCRIPTION	QTY.	CODE
19-	A50351A1						Sump Assembly, Oil .....	1	C
	A50351A2						Sump Assembly, Oil .....	1	C
-1	A50351	①					Sump Oil (part of A50351A1 & A50351A2) .....	1	C
-2	633233-27	②					Oil Gage and Cap Assy. (part of A50351A1) ...	1	C
-2	633233-10	②					Oil Gage and Cap Assy. (part of A50351A2) ...	1	C
-3	533355						Gasket .....	1	All
-3	633240						Gasket .....	1	All
-4	3577						Gasket .....	1	All
-5	532432						Plug, Hex Drilled Head .....	1	All
-6	AN900-10						Gasket, Copper Asbestos .....	1	All
ATTACHING PARTS									
-7	20522						Washer, Plain - to crankcase .....	6	All
-8	22661						Nut, Elastic Stop - to crankcase .....	6	All
-9	21213						Nut, Elastic Stop - to crankcase .....	1	All

**NOTES:**

- ① To obtain correct replacement oil sump, order same part number stamped on upper surface of original sump mount flange. Also give engine application.
- ② Rod and cap assemblies which contain a leaf spring, use P/N 633240 gasket, which is 1/8 inch thick. Rod and cap assemblies which contain a coil spring use P/N 533355 gasket, which is 1/16 inch thick.

SEE SECTION VI FOR SPECIFICATION APPLICATIONS.

FIG. INDEX	PART NUMBER	1 2 3 4 5	DESCRIPTION	QTY.	CODE
19-	A50331A2		Sump Assembly, Oil .....	1	AB
	A50337A1		Sump Assembly, Oil .....	1	B
	A50351A1		Sump Assembly, Oil .....	1	C
	A50351A2		Sump Assembly, Oil .....	1	C
	A50372A1		Sump Assembly, Oil .....	1	B
	A50374A2		Sump Assembly, Oil .....	1	B
	A5230A1		Sump Assembly, Oil .....	1	B
	A5230A2		Sump Assembly, Oil .....	1	BC
	A5230A3		Sump Assembly, Oil .....	1	ABC
	530473A1		Sump Assembly, Oil .....	1	C
	627374A1		Sump Assembly, Oil .....	1	C
-1	A50331	①	Sump, Oil (part of A50331A2) .....	1	AB
-1	A50331	①	Sump, Oil (part of A50337A1) .....	1	B
-1	A50351	①	Sump, Oil (part of A50351A1 & A50351A2) .....	1	C
-1	A50372	①	Sump, Oil (part of A50372A1) .....	1	B
-1	A50374	①	Sump, Oil (part of A50374A2) .....	1	B
-1	A5230	①	Sump, Oil (part of A5230A1, A5230A2 & A5230A3) .....	1	ABC
-1	530473	①	Sump, Oil (part of 530473A1) .....	1	C
-1	627374	①	Sump, Oil (part of 627374A1) .....	1	C
-2	633233-16	②	Oil Gage and Cap Assembly (part of A50331A2) .....	1	AB
-2	633233-28	②	Oil Gage and Cap Assembly (part of A50337A1) .....	1	B
-2	633233-27	②	Oil Gage and Cap Assy. (part of A50372A1 & A50351A1) .....	1	C
-2	633233-26	②	Oil Gage and Cap Assembly (part of A50374A2) .....	1	B
-2	633233-15	②	Oil Gage and Cap Assembly (part of A5230A1) .....	1	
-2	633233-17	②	Oil Gage and Cap Assembly (part of A5230A2) .....	1	BC
-2	633233-18	②	Oil Gage and Cap Assembly (part of A5230A3) .....	1	ABC
-2	633233-10	②	Oil Gage and Cap Assembly (part of A50351A2) .....	1	C
-2	633233-20	②	Oil Gage and Cap Assy. (part of 530473A1 & 627374A1) .....	1	C
-3	533355		Gasket .....	1	All
-3	633240		Gasket .....	1	All
-4	3577		Gasket .....	1	All
-5	532432		Plug, Hex Drilled Head .....	1	All
-6	AN900-10		Gasket, Copper Asbestos .....	1	All
ATTACHING PARTS					
-7	20522		Washer, Plain - to crankcase .....	6	All
-8	22661		Nut, Elastic Stop - to crankcase .....	6	All
-9	21213		Nut, Elastic Stop - to crankcase .....	1	All

NOTES:

- ① To obtain correct replacement oil sump, order same part number stamped on upper surface of original sump mount flange. Also give engine application.
- ② Rod and cap assemblies which contain a leaf spring, use P/N 633240 gasket, which is 1/8 inch thick. Rod and cap assemblies which contain a coil spring use P/N 533355 gasket, which is 1/16 inch thick.

SEE SECTION VI FOR SPECIFICATION APPLICATIONS



# SECTION III

## OVERSIZE AND UNDERSIZE PARTS LIST

PART NUMBER	NAME	OVERSIZE	PART NUMBER	NAME	OVERSIZE
21075P003	Stud	.003" OS on PD	401809P007	Stud	.007" OS on PD
21075P006	Stud	.006" OS on PD	401809P012	Stud	.012" OS on PD
21075P009	Stud	.009" OS on PD			
			401824P003	Stud	.003" OS on PD
21153P005	Shaft	.005" OS on OD	401824P007	Stud	.007" OS on PD
			401824P012	Stud	.012" OS on PD
22949P005	Bushing	.005" OS on OD			
22949P020	Bushing	.020" OS on OD	401870P003	Stud	.003" OS on PD
			401870P007	Stud	.007" OS on PD
24024P005	Guide	.005" OS on OD	401870P012	Stud	.012" OS on PD
24024P010	Guide	.010" OS on OD			
24024P020	Guide	.020" OS on OD	401874P003	Stud	.003" OS on PD
			401874P007	Stud	.007" OS on PD
24047P005	Guide	.005" OS on OD	401874P012	Stud	.012" OS on PD
24047P010	Guide	.010" OS on OD			
24047P020	Guide	.020" OS on OD	401881P003	Stud	.003" OS on PD
			401881P007	Stud	.007" OS on PD
25030P003	Stud	.003" OS on PD	401881P012	Stud	.012" OS on PD
25030P006	Stud	.006" OS on PD			
25030P009	Stud	.009" OS on PD	401893P003	Stud	.003" OS on PD
			401893P007	Stud	.007" OS on PD
25329P003	Stud	.003" OS on PD	401893P012	Stud	.012" OS on PD
25329P006	Stud	.006" OS on PD			
25329P009	Stud	.009" OS on PD	401954P003	Stud	.003" OS on PD
			401954P007	Stud	.007" OS on PD
25330P003	Stud	.003" OS on PD	401954P012	Stud	.012" OS on PD
25330P006	Stud	.006" OS on PD			
25330P009	Stud	.009" OS on PD	401963P003	Stud	.003" OS on PD
			401963P007	Stud	.007" OS on PD
3923P002	Insert	.002" OS on OD	401963P012	Stud	.012" OS on PD
3923P010	Insert	.010" OS on OD			
3923P020	Insert	.020" OS on OD	401971P003	Stud	.003" OS on PD
3923P030	Insert	.030" OS on OD	401971P007	Stud	.007" OS on PD
			401971P012	Stud	.012" OS on PD
401801P003	Stud	.003" OS on PD			
401801P007	Stud	.007" OS on PD	401975P003	Stud	.003" OS on PD
401801P012	Stud	.012" OS on PD	401975P007	Stud	.007" OS on PD
			401975P012	Stud	.012" OS on PD
401804P003	Stud	.003" OS on PD			
401804P007	Stud	.007" OS on PD	401977P003	Stud	.003" OS on PD
401804P012	Stud	.012" OS on PD	401977P007	Stud	.007" OS on PD
			401977P012	Stud	.012" OS on PD
401805P003	Stud	.003" OS on PD			
401805P007	Stud	.007" OS on PD	402032P003	Stud	.003" OS on PD
401805P012	Stud	.012" OS on PD	402032P007	Stud	.007" OS on PD
			402032P012	Stud	.012" OS on PD
401809P003	Stud	.003" OS on PD			

PART NUMBER	NAME	OVERSIZE	PART NUMBER	NAME	OVERSIZE
402040P003	Stud	.003" OS on PD	530058M010	Bearing	.010" US on ID
402040P007	Stud	.007" OS on PD			
402040P012	Stud	.012" OS on PD	530348P015	Piston	.015" OS on OD
402042P003	Stud	.003" OS on PD	531076P020	Camshaft	.020" OS on OD
402042P007	Stud	.007" OS on PD			
402042P012	Stud	.012" OS on PD	531146P020	Camshaft	.020" OS on OD
402044P003	Stud	.003" OS on PD	537870P030	Push Rod	.030" OS on OD
402044P007	Stud	.007" OS on PD			
402044P012	Stud	.012" OS on PD	626608P020	Camshaft	.020" OS on OD
402045P003	Stud	.003" OS on PD	627246A1M010	Bearing Set	.010" US on ID
402045P007	Stud	.007" OS on PD			
402045P012	Stud	.012" OS on PD	628309P005	Guide	.005" OS on OD
			628309P010	Guide	.010" OS on OD
402047P003	Stud	.003" OS on PD	628309P020	Guide	.020" OS on OD
402047P007	Stud	.007" OS on PD			
402047P012	Stud	.012" OS on PD	630651P005	Dowel	.005" OS on OD
402048P003	Stud	.003" OS on PD	633181P003	Stud	.003" OS on PD
402048P007	Stud	.007" OS on PD	633181P007	Stud	.007" OS on PD
402048P012	Stud	.012" OS on PD	633181P012	Stud	.012" OS on PD
402049P003	Stud	.003" OS on PD	633398M010	Bearing	.010" US on ID
402049P007	Stud	.007" OS on PD			
402049P012	Stud	.012" OS on PD	633399M010	Bearing	.010" US on ID
402131P003	Stud	.003" OS on PD	638109A1P005	Ring Set	.005" OS on OD
402131P007	Stud	.007" OS on PD	638109A1P015	Ring Set	.015" OS on OD
402131P012	Stud	.012" OS on PD			
402151P003	Stud	.003" OS on PD	638109P005	Ring	.005" OS on OD
402151P007	Stud	.007" OS on PD	638109P015	Ring	.015" OS on OD
402151P012	Stud	.012" OS on PD	638110P005	Ring	.005" OS on OD
			638110P015	Ring	.015" OS on OD
402711P003	Stud	.003" OS on PD	638111P005	Ring	.005" OS on OD
402711P007	Stud	.007" OS on PD	638111P015	Ring	.015" OS on OD
402711P012	Stud	.012" OS on PD			
40327P015	Piston	.015" OS on OD	639640M010	Bearing	.010" US on ID
40584P020	Camshaft	.020" OS on OD	641793P002	Insert	.002" OS on OD
			641793P005	Insert	.005" OS on OD
530058A1M010	Bearing Set	.010" US on ID	641793P010	Insert	.010" OS on OD
530058A2M010	Bearing Set	.010" US on ID	641793P020	Insert	.020" OS on OD
			641793P030	Insert	.030" OS on OD
530058A6M010	Bearing Set	.010" US on ID			



## SECTION IV

# REPAIR PARTS SETS AND MATERIALS

PART NUMBER	DESCRIPTION	SIZE
642188	Gasket Paste - Tite Seal (lightweight) .....	1 oz. tube
24890A2	Gasket and Rubber Connector Set (for-12 Models and O-200)	—
24890A4	Gasket and Rubber Connector Set (for - 8 Models) .....	—
530058A1	Bearing Set (C75, C85, C90 with Dowel on Thrust Washer) ...	Standard
530058A1M010	Bearing Set .....	.010" Undersize
530058A2	Bearing Set (For Crankcases with Dowels Installed in Front Bearing Boss C75, C85, C90) .....	Standard
530058A2M010	Bearing Set .....	.010" Undersize
530058A6	Bearing and Thrust Washer Set (Main) O-200 with 633141 Thrust Washer .....	Standard
530058A6M010	Bearing and Thrust Washer Set .....	.010" Undersize
627246A1	Bearing Set (Main) with Flanged Thrust Bearing (for O-200) ..	Standard
627246A2M010	Bearing Set .....	.010" Undersize
638109A1	Ring Set-Complete Piston (for all C75, C85, C90 & O-200 Models)	Standard
638109A1P005	Ring Set .....	.005" Oversize
638109A1P010	Ring Set .....	.010" Oversize
638109A1P015	Ring Set .....	.015" Oversize
639721	* Ring Set .....	Standard
626531-1	Enamel - Gold .....	1 Quart
626531-2	Enamel - Gold .....	1 Gallon

NOTE \* Chrome Plate



# SECTION V NUMERICAL PARTS LIST

PART NUMBER	FIGURE & INDEX	QTY PER ASSY
-------------	----------------------	--------------------

PART NUMBER	FIGURE & INDEX	QTY PER ASSY
-------------	----------------------	--------------------

AN123864	14-11	1	A50337A1	19-00	1
AN392-11	04-20	1	A50351	19-01	1
AN4-11A	02-02	10	A50351	19-01	1
AN4022-1	12-17	1	A50351A1	19-00	1
AN501A10-5	12-36	2	A50351A1	19-00	1
AN502-10-8	08-16	6	A50351A2	19-00	1
AN805-2	12-19	1	A50351A2	19-00	1
AN842-10	03-01	1	A50372	19-01	1
AN900-10	01-20	2	A50372A1	19-00	1
AN900-10	10-24	1	A50374	19-01	1
AN900-10	10-34	1	A50374A2	19-00	1
AN900-10	11-22	1	A50495	12-27	1
AN900-10	11-23	1	A5230	19-01	1
AN900-10	17-10	1	A5230A1	19-00	1
AN900-10	19-06	1	A5230A2	19-00	1
AN900-10	19-06	1	A5230A3	19-00	1
AN900-14	10-32	1	EQ5334	17-00	Opt
AN900-14	11-18	1	MS21044N06	15-31	2
AN900-28	10-22	1	MS24665-132	14-19	1
AN900-28	11-20	1	MS24665-155	12-05	2
AN911-1	18-18	1	MS35337-44	03-10	12
AN918-1D	18-19	1	MS35337-44	03-36	3
A21599	08-00	8	MS35337-44	03-44	4
A22301	10-35	1	MS35337-44	09-30	6
A22301	11-24	1	MS35337-44	12-10	8
A24197	18-17	2	MS35337-44	12-23	4
A24706	18-20	1	MS35337-44	12-34	4
A25277	15-04	2	MS35337-45	03-17	3
A35160A2	06-00	4	MS35337-45	03-39	1
A3568	10-23	1	MS35337-45	10-11	7
A3568	11-21	1	MS35337-45	13-13	Ref
A35917	12-35	1	MS35337-45	14-04	5
A3746	04-11	1	MS35337-45	14-08	3
A40522	12-26	1	MS35337-45	15-11	4
A40793	12-26	1	MS35337-45	16-03	4
A4587	11-01	1	MS35338-45	03-05	2
A50256	12-27	1	MS35338-45	11-05	10
A50329	18-24	1	MS35338-45	17-04	RF
A50330	18-24	1	MS9088-08	08-16	6
A50331	19-01	1	MS9134-1	03-41	1
A50331	19-01	1	X2235	03-29	1
A50331A2	19-00	1	20087	15-17	4

PART NUMBER	FIGURE & INDEX	QTY PER ASSY
-------------	----------------	--------------

2024	01-22	1
2024	12-16	1
2024	17-07	1
2025	10-09	1
20522	02-01	22
20522	02-07	1
20522	02-07	3
20522	03-09	12
20522	03-35	3
20522	10-16	4
20522	10-20	3
20522	10-28	3
20522	11-10	4
20522	12-09	8
20522	12-22	4
20522	15-45	2
20522	18-05	4
20522	19-07	6
20720	12-18	1
21007	02-19	6
21007	09-25	1
21051	12-20	1
21075	01-16	1
21080	01-23	2
21082	15-35	AR
21113	10-33	1
21113	11-19	1
21114	10-30	1
21114	11-16	1
21153	09-26	1
21160	11-09	1
21182	12-12	4
21185	12-13	8
21202	04-18	1
21203	04-19	1
21208A2	11-13	1
21213	19-09	1
21218	02-08	1
21264	15-29	1
21264	15-48	2
21284	09-12	2
21323	12-25	1
21343	11-08	1
21346	04-09	4
21346	05-11	4
21346	08-12	4
21361	09-22	4
21459	15-26	2
21468	04-14	6
21477	09-01	4

PART NUMBER	FIGURE & INDEX	QTY PER ASSY
-------------	----------------	--------------

21493	09-32	4
21530	03-22	4
21608	08-01	1
21619	18-25	1
22022	09-33	8
22030	08-14	AR
22031	08-15	AR
22133	17-13	1
22250	12-06	4
22344	03-14	1
22344	17-02	RF
22350	10-18	1
22354	10-13	1
22355	10-14	1
22387	03-21	8
22493	15-43	2
22495	15-46	6
22532	04-09	4
22532	05-11	4
22534	08-11	4
22537	10-17	4
22537	11-11	4
22661	10-29	3
22661	19-08	6
22800	12-14	8
22949	09-34	AR
2306	15-40	4
23166	18-12	2
23410	10-15	1
23487	03-19	1
24024	09-08	1
24026	09-16	1
24027	09-21	2
24029	09-19	2
24031	09-18	2
24044	09-17	1
24047	09-09	1
24122	09-24	1
24251	02-02	10
24252	02-12	2
24306	12-29	4
24308	12-30	4
24321	04-10	1
2437	02-03	12
2437	02-10	2
2437	03-11	12
2437	03-37	3
2437	03-45	4
2437	10-21	3
2437	12-11	8

PART NUMBER	FIGURE & INDEX	QTY PER ASSY
-------------	----------------	--------------

PART NUMBER	FIGURE & INDEX	QTY PER ASSY
-------------	----------------	--------------

2437	03-37	3
2437	03-45	4
2437	10-21	3
2437	12-11	8
2437	12-24	4
2437	12-33	4
2439	03-06	2
2439	03-18	3
2439	03-40	1
2439	10-12	7
2439	11-06	10
2439	13-15	Ref
2439	14-06	3
2439	14-09	3
2439	15-12	4
2439	16-04	4
2439	17-05	RF
2441	02-14	1
2441	17-15	3
2443	02-17	2
24434	18-03	1
24456	18-14	2
2456	11-12	4
2458	04-16	6
2458	12-04	2
2458	18-06	4
2471	12-37	2
2471	18-10	2
2471	18-13	2
2472	02-06	1
2472	02-11	2
2472	03-43	4
2473	03-04	2
2473	03-16	3
2473	03-38	1
2473	10-10	7
2473	11-04	10
2473	13-14	Ref
2473	14-05	5
2473	17-03	Ref
2473	18-09	2
2474	04-15	6
2474	17-14	3
2475	02-16	2
24768	05-17	6
24769	05-01	6
24770	05-02	1
24804	06-04	2
24878	02-09	1
24879	02-04	1
24915	18-08	1

24945	18-23	1
24946	18-21	1
24947	18-15	4
2500	04-21	1
25030	01-14	1
25030	01-15	1
2506	04-17	6
25102	03-34	1
25145	15-47	2
25164	02-05	2
25301	15-15	AR
25302	15-16	4
25305	15-18	1
25305	15-36	1
25314	15-05	1
25315	15-06	2
25316	15-07	1
25317	15-08	1
25318	15-09	1
25320	15-33	8
25320	15-42	4
25321	15-32	8
25321	15-41	4
25329	01-17	4
25330	01-18	2
25369	06-01	1
25387	15-21	4
25387	15-39	4
25388	15-20	4
25388	15-38	4
2557	12-04	2
2848	17-09	1
2849	17-08	1
35016	04-08	1
35016	05-10	1
35018	10-27	1
35019	10-25	1
35019	14-07	Ref
35020	10-19	1
35033	03-15	1
3506	08-09	1
35145A1	12-00	1
352030	13-19	1
352030	14-14	1
352068	14-12	1
352179	14-01	1
3562	11-07	1
3577	19-04	1
35798	18-16	1
35923	12-31	1
35956	05-14	1

PART NUMBER	FIGURE & INDEX	QTY PER ASSY
-------------	----------------	--------------

36066	15-03	1
36066	16-06	2
36067	15-04	1
36104	18-11	1
36151N	12-15	16
3660	08-13	1
3745	04-12	1
3923	09-06	1
3991	04-13	1
3991	05-15	1
401506	15-10	4
401507	02-13	1
401507	05-16	6
401753	17-06	2
401801	01-08	3
401801	10-03	1
401801	10-05	2
401804	01-04	12
401804	10-06	1
401804	10-07	3
401804	11-02	3
401805	18-04	4
401809	01-06	3
401809	01-11	10
401824	11-03	4
401870	01-19	3
401870	09-11	2
401874	01-16	1
401881	01-15	1
401893	12-01	4
401954	01-10	2
401963	03-32	4
401971	10-08	3
401975	10-02	4
401977	10-10	2
402032	01-10	2
402040	01-03	8
402042	01-14	1
402044	10-04	2
402045	18-02	2
402047	01-12	5
402048	01-07	1
402049	01-13	2
402049	01-13	3
402131	10-02	4
402151	01-05	2
402151	01-09	1
402151	09-10	2
40246	12-07	2
40247	12-08	2
402711	12-32	4

PART NUMBER	FIGURE & INDEX	QTY PER ASSY
-------------	----------------	--------------

40327	07-01	4
40452	18-07	1
40584	08-05	1
40585	18-22	Opt
40599	12-28	1
40762	09-28	1
40794	15-19	1
40794	15-37	1
4577	11-01	1
4763	17-01	1
500398	04-01	1
500400	04-11	1
50207A1	18-01	Opt
50309	14-02	1
50483	15-02	2
520112	09-07	2
530019	05-12	1
530058	04-03	2
530058	05-04	2
530059	15-27	4
530061	15-13	1
530061A2	15-12	1
530062	15-14	1
530162	09-27	1
530163	03-08	4
530182	05-00	1
530184A2	06-00	4
530192	06-01	1
530196A1	04-00	1
530199A1	15-00	1
530209	15-02	2
530213	06-03	2
530264	17-12	1
530348	07-02	4
530375	15-13	1
530375A1	15-12	1
530376	15-14	1
530406	13-17	1
530406	14-13	1
530407	13-18	1
530407	14-16	1
530412	13-22	1
530412	14-18	1
530473	19-01	1
530473A1	19-00	1
530535	08-10	1
530626	03-25	8
530627	03-24	4
530641	04-08	1
530641	05-09	1
530642	03-02	1

PART NUMBER	FIGURE & INDEX	QTY PER ASSY
-------------	----------------------	--------------------

530700A1	15-34	1
530740	03-26	8
530741	03-27	8
530830	07-07	4
530851	08-01	1
530872	08-00	8
530873	08-01	1
530886	15-28	2
530886	15-44	2
530928	03-07	4
530940	08-04	1
530956	05-13	1
531001	09-03	16
531003	09-02	8
531076	08-05	1
531146	08-06	1
531325	13-21	1
531325	14-17	1
532148	15-22	4
532149	15-23	4
532151	15-24	4
532432	01-21	2
532432	17-11	1
532432	19-05	1
532432	19-05	1
533355	19-03	1
533965	03-03	1
534111	14-10	1
534208	14-07	1
534471	09-29	6
534750	16-01	2
535091	09-31	6
535324	15-01	2
536388-1.25	03-13	16
537870	08-08	8
538556	12-02	2
538556	12-03	2
538999	14-03	2
539840	03-12	8
5484	10-01	1
625935	03-31	1
625937	03-28	1
625958	09-20	2
626543	14-15	2
626608	08-07	1
626983	03-30	1
627275	02-15	2
627307A10	10-01	1
627307A10	10-01	1
627358A2	01-01	1
627359A2	01-01	1

PART NUMBER	FIGURE & INDEX	QTY PER ASSY
-------------	----------------------	--------------------

627360A2	01-01	1
627361	12-27	1
627366	12-21	1
627367	12-21	1
627374	19-01	1
627374A1	19-00	1
627429	09-32	Opt
627667A1	15-34	1
627728	18-24	1
627759	15-30	2
628195A1	01-01	1
628309	09-09	1
628555-16	03-23	4
628986	15-23	4
629404	09-15	1
629518-1H	01-22	1
629518-1H	09-13	1
630651	04-07	1
630651	05-08	1
630966-3.31	13-12	2
631391	18-22	Opt
631639	09-15	1
632050	13-20	2
632085	11-15	1
632330	03-33	1
632501	15-34	8
632503	15-34	8
632503	16-32	Ref
633028	12-21	1
633122	16-05	2
633141	04-02	4
633141	05-03	4
633163	16-06	1
633181	01-02	8
633233-10	19-02	1
633233-10	19-02	1
633233-15	19-02	1
633233-16	19-02	1
633233-17	19-02	1
633233-18	19-02	1
633233-20	19-02	1
633233-26	19-02	1
633233-27	19-02	1
633233-27	19-02	1
633233-28	19-02	1
633240	19-03	1
633398	04-04	2
633398	05-05	2
633399	04-05	2
633581	16-22	1
633582	16-21	1

PART NUMBER	FIGURE & INDEX	QTY PER ASSY
-------------	----------------------	--------------------

633583	16-14	1
633583	16-20	1
633584	16-19	1
633585	16-11	1
633585	16-17	1
633586	16-12	1
633586	16-18	1
633609-8	03-19B	1
633661	13-16	1
633924	16-28	2
633925	16-27	4
633926	16-31	Ref
633927	16-29	2
634337	16-16	1
634338	16-13	1
634339	16-15	1
634342	16-07	1
634342	16-08	1
634342	16-09	1
634342	16-10	1
634342	16-23	1
634342	16-24	1
634342	16-25	1
634342	16-26	1
634464	13-11	1
636687	16-30	2
637083	10-31	1
637083	11-17	1
637268	08-03	1
637269	08-02	1
637270	08-00	8
637832	03-20	2
638109	07-03	4
638110	07-04	4
638110	07-05	4
638111	07-06	4
639292	06-05	8
639292	13-23	1

PART NUMBER	FIGURE & INDEX	QTY PER ASSY
-------------	----------------------	--------------------

639297	13-23	1
639298	13-23	1
639614	09-23	1
639615	09-23	1
639640	04-06	8
639640	05-07	8
639788	13-08	2
639789	13-06	1
639970	13-04	1
640033	13-05	2
640036	13-09	1
640174	13-10	1
640296	07-03	Opt
640296	07-04	Opt
640297	07-05	Opt
640298	07-06	Opt
640380	03-42	1
641497	13-02	1
641498	13-07	1
641499	13-03	1
641500	13-01	1
641792	09-14	1
641793	09-05	1
641916	09-04	1
641916A1	09-01	4
641917	09-04	1
641917A2	09-01	4
641917CP	09-04	Opt
641917CP-A2	09-01	Opt
642370	16-02	4
642714	10-26	1
642714	11-14	1
643231	03-19A	1
643233	05-06	2
643250	01-01	1



# SECTION VI

## CUSTOMER SPECIFICATIONS

The following pages contain the various customer specifications of the basic O-200-A aircraft engines. The figure and index column refers to an illustrated view of the parts or assembly differences. Figures 20 thru 22 are located on page 2-6 in the rear of this section. The other figures referenced in this section are located throughout Section II.

In some instances, certain accessories are furnished by the aircraft manufacturer. If an accessory on the engine does not appear on the customer spec, determine whether it is available from the aircraft manufacturer.

MODEL SPEC	PART NUMBER	1 2 3 4 5	DESCRIPTION	QTY.	FIGURE INDEX
O-200-A1	641534		Housing Assembly, Carburetor Air .....	1	12-27
	641527		. Bushing .....	2	Not. Illus
	A50351A2		Sump Assembly (See Fig. 19) .....	1	19-
O-200-A2	637307A3		Cover Assembly, Crankcase .....	1	10-
	401804		Stud, 1/4 x 1-1/16 Inch Long .....	1	10-3
	401804		. Stud, 1/4 x 1-1/16 Inch Long .....	3	10-5
	21163		Seal, Oil, Tach Drive .....	1	10-26
	2474		Washer, Plain 3/8 Inch .....	2	12-2
	630979-1		O-Ring .....	2	12-3
	627143		Carburetor .....	1	12-21
O-200-A9	641534		Housing Assembly, Carburetor Air .....	1	12-27
	641527		. Bushing .....	2	Not. Illus.
	EQ5820		Generator Drive Equipment .....	1	14-
	A50351A2		(includes parts listed in Fig. 14-11 thru 19) Sump Assy., Oil (see fig. 19 for attaching parts)	1	19-
O-200-A10	628422A1		Studding Assembly, Crankcase .....	1	1-1
	401977	†	. Stud, 3/8 x 2-2/32 Inch Long .....	2	1-10
	402049	†	. Stud, 5/16 x 3-3/4 Inch Long .....	2	1-13
	401881	†	. Stud, 5/16 x 1-1/8 Inch Long .....	2	1-14/15
	401874	†	. Stud, 3/8 x 5 Inch Long .....	1	1-16
	628018		Cover, Vacuum Pump Pad .....	1	20-1
	2474		Washer .....	6	5-15
	24768		Bolt .....	6	5-16
	628421		Camshaft .....	1	8-7
	21492		Flange Exhaust .....	4	21-1
	A50352A1		Sump Assembly, Oil .....	1	19-
	A50352		. Sump .....	1	19-1
	633233-19		. Rod & Cap Assy., Oil Gage .....	1	19-2
O-200-A12	628422A1		Studding Assembly, Crankcase .....	1	1-1
	401977	†	. Stud, 3/8 x 2-2/32 Inch Long .....	2	1-10
	402049	†	. Stud, 5/16 x 3-3/4 Inch Long .....	2	1-13
	401881	†	. Stud, 5/16 x 1-1/8 Inch Long .....	2	1-14/15
	401874	†	. Stud, 3/8 x 5 Inch Long .....	1	1-16
	628018		Cover, Vacuum Pump Pad .....	1	20-1
	2474		Washer .....	6	5-15
	24768		Bolt .....	6	5-16
	628421		Camshaft .....	1	8-7
	21492		Flange, Exhaust .....	4	21-1
	A50352A1		Sump Assembly, Oil .....	1	19-
	A50352		. Sump .....	1	19-1
	633233-19		. Rod & Cap Assy., Oil Gage .....	1	19-2
O-200-A14	641534		Housing Assembly, Carburetor Air .....	1	12-27
	641527		. Bushing .....	2	Not Illus.
	536035		Generator - Delco 35 Amp 12 Volt .....	1	14-10
	627322		Regulator .....	1	14-20
	A50351A2		Sump Assy. Oil (see fig. 19 for attaching parts) .....	1	19-

MODEL SPEC	PART NUMBER	1 2 3 4 5	DESCRIPTION	QTY.	FIGURE INDEX
O-200-A23	628422A3		Studding Assembly, Crankcase .....	1	1-
	401804	†	. Stud, 1/4 x 1-1/16 Inch Long .....	15	1-4/19
	401881	†	. Stud, 5/16 x 1-1/8 Inch Long .....	1	1-9
	401881	†	. Stud, 5/16 x 1-1/8 Inch Long .....	2	1-14/15
	630403		Gear, Vacuum Pump Drive .....	1	8-13
	536035		Generator, 35 Amp 12 Volt .....	1	14-10
	536451		Regulator, Voltage .....	1	14-20
	536453		Relay .....	1	22-1
	2024		Plug, Fuel Pump Inlet & Outlet .....	2	18-23/25
O-200-A24	628422A1		Studding Assembly, Crankcase .....	1	1-
	401977	†	. Stud, 3/8 x 2-2/32 Inch Long .....	2	1-10
	402049	†	. Stud, 5/16 x 3-3/4 Inch Long .....	2	1-13
	401881	†	. Stud, 5/16 x 1-1/8 Inch Long .....	2	1-14/15
	401874	†	. Stud, 3/8 x 5 Inch Long .....	1	1-16
	628018		Cover, Vacuum Pump Pad .....	1	3-42
	628421		Camshaft .....	1	8-7
	21492		Flange, Exhaust .....	4	21-1
	A50352A1		Sump Assembly, Oil .....	1	19-
	A50352		. Sump .....	1	19-1
	633233-19		. Rod & Cap Assembly, Oil Gage .....	1	19-2
	O-200-A26	628422A1		Studding Assembly, Crankcase .....	1
401977		†	. Stud, 3/8 x 2-2/32 Inch Long .....	2	1-10
402049		†	. Stud, 5/16 x 3-3/4 Inch Long .....	2	1-13
401881		†	. Stud, 5/16 x 1-1/8 Inch Long .....	2	1-14/15
401874		†	. Stud, 3/8 x 5 Inch Long .....	1	1-16
628018			Cover, Vacuum Pump Pad .....	1	3-42
628421			Camshaft .....	1	8-7
21492			Flange, Exhaust .....	4	21-1
A50352A1			Sump Assembly, Oil .....	1	19-
A50352			. Sump .....	1	19-1
633233-19			. Rod & Cap Assy., Oil Gage .....	1	19-2
O-200-A30		628422A1		Studding Assembly, Crankcase .....	1
	401977	†	. Stud, 3/8 x 2-2/32 Inch Long .....	2	1-10
	402049	†	. Stud, 5/16 x 3-3/4 Inch Long .....	2	1-13
	401881	†	. Stud, 5/16 x 1-1/8 Inch Long .....	2	1-14/15
	401874	†	. Stud, 3/8 x 5 Inch Long .....	1	1-16
	628018		Cover Vacuum Pump Pad .....	1	3-42
	2474		Washer, Plain .....	6	5-15
	24768		Bolt .....	6	5-16
	21492		Flange, Exhaust .....	4	21-1
	628421		Camshaft .....	1	8-7
	A50352A1		Sump Assembly, Oil .....	1	19-
	A50352		. Sump .....	1	19-1
	633233-19		. Rod & Cap Assy., Oil Gage .....	1	19-2
O-200-A32	641534		Housing Assy., Carburetor Air .....	1	12-27
	641527		. Bushing .....	2	Not Illus.
	536035		Generator - Delco 35 Amp, 12 Volt .....	1	14-10
	2502		Pin, cotter .....	1	14-19
	627322		Regulator .....	1	14-20
	A50351A2		Sump Assy., Oil (see fig. 19 for attaching parts)	1	19-

MODEL SPEC	PART NUMBER	1 2 3 4 5	DESCRIPTION	QTY.	FIGURE INDEX
O-200-A33	628421		Camshaft .....	1	8-7
	627143		Carburetor .....	1	12-21
	35145A1		Manifold Assy., Intake .....	1	12-
	2024		Plug .....	2	12-16/17
	2474		Washer .....	2	12-2
	630979-7		O-Ring .....	2	12-3
O-200-A36	627201A1		Studding Assembly, Crankcase .....	1	1-
	401804	†	. Stud, 1/4 x 1-1/16 Inch Long .....	12	1-4
	401804	†	. Stud, 1/4 x 1-1/16 Inch Long .....	3	1-8
	401804	†	. Stud, 1/4 x 1-1/16 Inch Long .....	3	1-19
	402048	†	. Stud, 5/16 x 3-11/16 Inch Long .....	1	1-7
	401977	†	. Stud, 3/8 x 2-2/32 Inch Long .....	2	1-10
	401881	†	. Stud, 5/16 x 1-1/8 Inch Long .....	1	1-9
	401881	†	. Stud, 5/16 x 1-1/8 Inch Long .....	2	1-14/15
	536035		Generator, 35 Amp 12 Volt .....	1	14-10
	627322		Regulator, Voltage .....	1	14-20
	642487		Magneto, Slick .....	2	16-5
	630535		Washer, Magneto Hold Down .....	4	16-2
	MS35333-41		Washer, Lock .....	4	16-3
	633914		Harness Assembly, RH .....	1	16-
	633915		Harness Assembly, LH .....	1	16-
	634341		. Sleeve, Insulator .....	1	16-19
	634340		. Cap End (Dist. Cap) .....	1	Not Illus.
	A50351A2		Sump Assy., Oil (see fig. 19 for attaching parts)	1	19-
	O-200-A38	641534		Housing Assy., Carburetor Air .....	1
641527			. Bushing .....	2	Not Illus.
EQ5820			Generator Drive Equipment (includes parts listed in fig. 14-11 thru 19)		
633401			Magneto, Slick .....	2	16-
633914			Harness Assembly, RH .....	1	16-
633915			Harness Assembly, LH .....	1	16-
634341			. Slick, Insulator .....	1	16-19
634340			. Cap, End (Dist. Cap) .....	1	Not Illus.
A50351A2			Sump Assy., Oil (see fig. 19 for attaching parts)	1	19-
O-200-A41	642487		Magneto, Slick .....	2	16-
	633914		Harness Assembly, RH .....	1	16-
	633915		Harness Assembly, LH .....	1	16-
O-200-A42	641534		Housing Assembly, Carburetor Air .....	1	12-27
	641527		. Bushing .....	2	Not Illus.
	642487		Magneto .....	2	16-
	639292		. Pin, Cotter - Nut to Mag Shaft .....	2	Not. Illus.
	633914		Harness Assembly, RH .....	1	16-
	633915		Harness Assembly, LH .....	1	16-
	A50351A2		Sump Assy., Oil (see fig. 19 for attaching parts)	1	19-
O-200-A47	641534		Housing Assembly, Carburetor Air .....	1	12-27
	641527		. Bushing .....	2	Not Illus.
	642487		Magneto .....	2	16-
	639292		. Pin Cotter - Nut to Mag Shaft .....	2	Not Illus.
	633914		Harness Assembly, RH .....	1	16-
	633915		Harness Assembly, LH .....	1	16-
	A50351A2		Sump Assy., Oil (see fig. 19 for attaching parts)	19-	

MODEL SPEC	PART NUMBER	1 2 3 4 5	DESCRIPTION	QTY.	FIGURE INDEX
O-200-A48	639292	.	Pin, Cotter - Nut to Magneto Shaft .....	2	Not Illus.
	627643		Plug, Spark .....	8	16-32
	A50351A2		Sump Assy., Oil (see fig. 19 for attaching parts)	1	19-
	633233-21	.	Rod & Cap Assy., Oil Gage .....	1	19-2
O-200-A52	21492		Flange, Exhaust .....	4	21-1
	641534		Housing Assy, Carburetor Air .....	1	12-27
	641527	.	Bushing .....	2	Not Illus.
	536035		Generator, 35 Amp 12 Volt .....	1	14-10
	2502		Pin, Cotter .....	1	14-19
	642487		Magneto .....	2	16
	639292	.	Pin cotter - Nut to Mag. Shaft .....	2	Not Illus.
	633914		Harness Assembly, RH .....	1	16-
	633915		Harness Assembly, LH .....	1	16-
	A50351A2		Sump Assy., Oil (see fig. 19 for attaching parts)	1	19-
O-200-A54G	643231		Adapter Assembly, Starter Clutch .....	1	3-19A
	642330		Spacer, Engine Mount .....	4	3-24
	641906		Gear, Cluster, Crankshaft .....	1	5-10
	35145A1		Manifold Assembly, Intake .....	1	12-
	2024		Plug .....	2	12-16/17
	640416		Carburetor, Marvel Schebler .....	1	12-21
	641534		Housing Assembly, Carburetor Air .....	1	12-27
	641527	.	Bushing .....	2	Not Illus.
	642487		Magneto .....	2	16-
	639292	.	Pin, Cotter - Nut to Mag. Shaft .....	2	Not Illus.
	633914		Harness Assembly, RH .....	1	16-
	633915		Harness Assembly, LH .....	1	16-
	627643		Plug, Spark .....	8	16-32
	A50351A2		Sump Assy., Oil (see fig. 19 for attaching parts)	1	19-
	633233-21	.	Rod & Cap Assy, Oil Gage .....	1	19-2
O-200-A57	628422A10		Studding Assembly, Crankcase .....	1	1-
	402044	†	Stud, 5/16 x 1-3/8 Inch Long .....	3	1-6
	402048	†	Stud, 5/16 x 3-11/16 Inch Long .....	1	1-7
	401893	†	Stud, 1/4 x 1-1/4 Inch Long .....	3	1-8
	401881	†	Stud, 5/16 x 1-1/8 Inch Long .....	1	1-9
	401977	†	Stud, 3/8 x 2-3/32 Inch Long .....	2	1-10
	402049	†	Stud, 5/16 x 3-3/4 Inch Long .....	2	1-13
	401881	†	Stud, 5/16 x 1-1/8 Inch Long .....	2	1-14/15
	401804	†	Stud, 1/4 x 1-1/16 Inch Long .....	3	1-19
	633182		Elbow Assy., Breather Crankcase .....	1	3-1
	643231		Adapter Assy., Starter Clutch .....	1	3-19A
	641906		Gear Cluster, Crankshaft .....	1	5-10
	630403		Gear, Vacuum Pump Drive .....	1	8-13
	641534		Housing, Assy, Carburetor Air .....	1	12-27
	641527	.	Bushing .....	2	Not Illus.
	640622		Alternator Assembly .....	1	13-16
	642487		Magneto .....	2	16-
	639292	.	Pin, Cotter - Nut to Mag. Shaft .....	2	Not Illus.
	633914		Harness Assembly, RH .....	1	16-
	633915		Harness Assembly, LH .....	1	16-
	627643		Plug, Spark .....	8	16-32
	2024		Plug .....	2	18-23/25
	A50351A2		Sump Assembly, Oil .....	1	19-

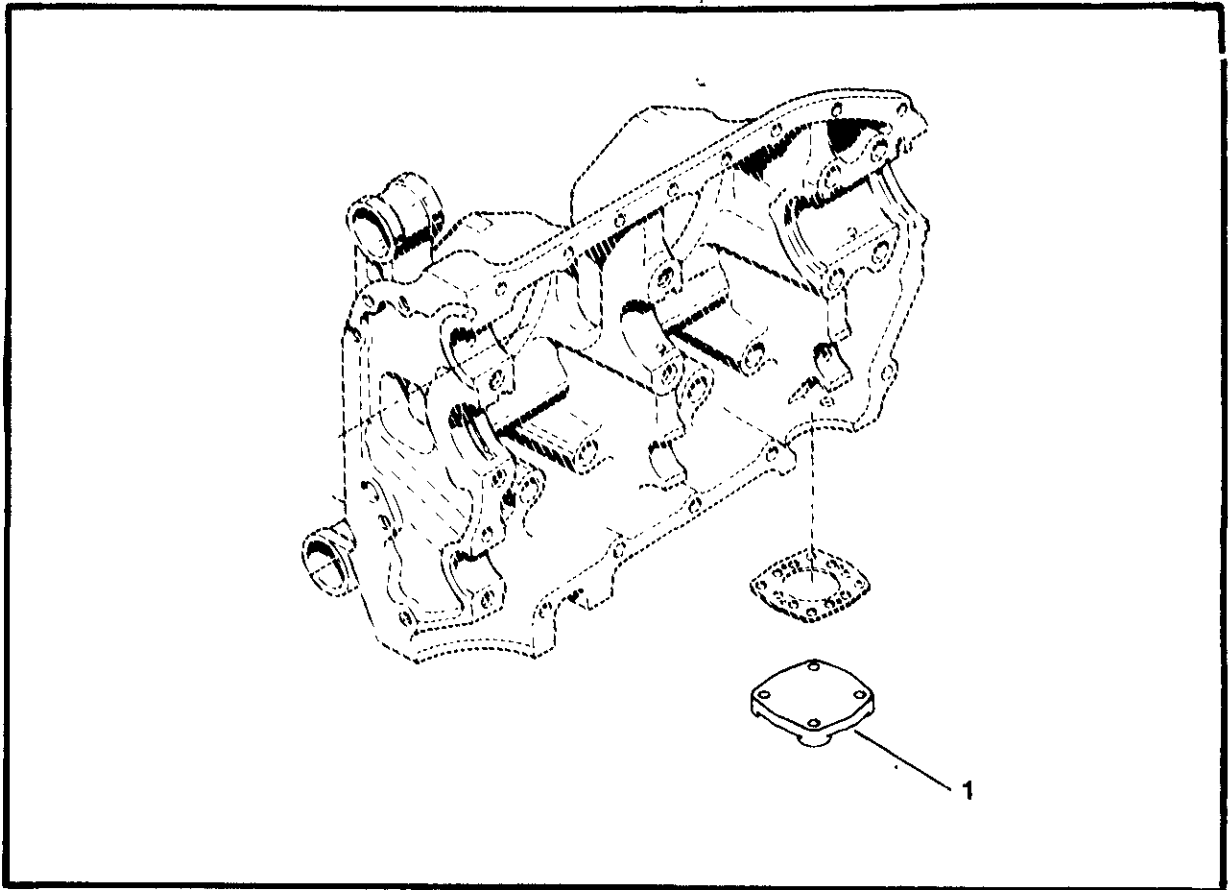

FIGURE 20. COVER, VACUUM PUMP PAD

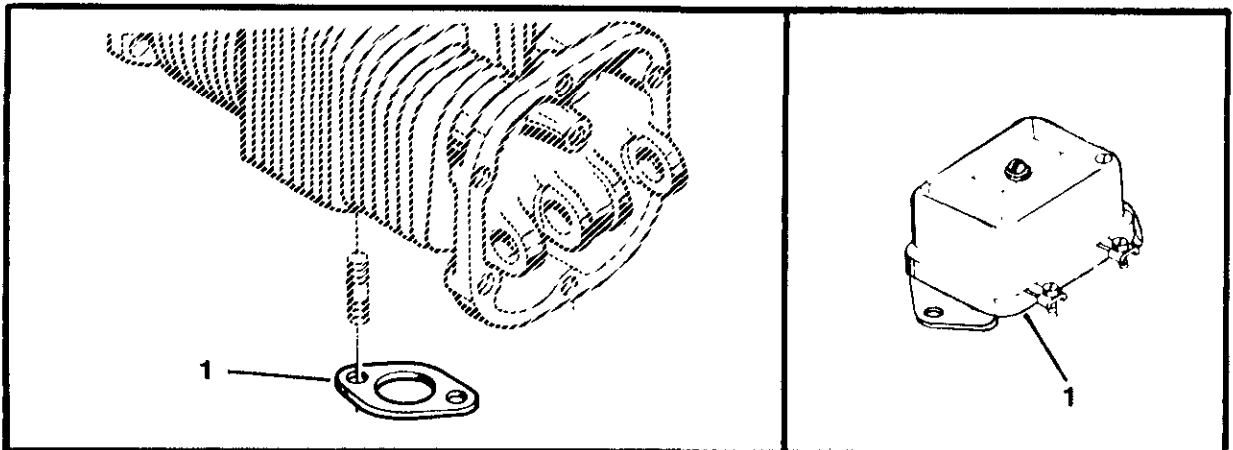

FIGURE 21. FLANGE, EXHAUST

FIGURE 22. RELAY

# **SECTION VII**

## **O-200-B BASIC AND CUSTOMERS SPECIFICATIONS**

The following pages contain, the various customer specifications of the basic O-200 B Aircraft Engines. The Figure and Index column refers to an illustrated view of the parts of assembly differences. Figures 23 thru 24 are located on page 7-3/7-4 in the rear of this section. The other Figures referenced in this section are located throughout Section II

In some instances, certain accessories are furnished by the aircraft manufacturer. If an accessory on the engine does not appear on the customer spec. determine whether it is available from the aircraft manufacturers.

MODEL SPEC	PART NUMBER	1 2 3 4 5	DESCRIPTION	QTY.	FIGURE INDEX
O-200-B	632132A1		Crankcase Studding Assembly .....	1	1-1
	401804	†	. Stud .....	18	1-4/8/19
	531434		Crankshaft Assembly .....	1	5-
O-200-B1	21492		Flange, Exhaust .....	1	24-1
	536035		Generator - Delco 35 Amp 12 Volt .....	1	14-10
	627322		Regulator .....	1	14-20
	A50351A2		Sump Assy., Oil (see fig. 19 for attaching parts)	1	-19
O-200-B2	628018		Cover, Vacuum Pump .....	1	23-1
	628421		Camshaft .....	1	8-7
	A50351A2		Sump Assembly, Oil .....	1	19-
O-200-B5	628018		Cover, Vacuum Pump .....	1	23-1
	628421		Camshaft .....	1	8-7
	A50351A2		Sump Assembly, Oil .....	1	19-
O-200-B8	629227A4		Crankcase Assembly .....	1	1-
	402151	†	. Stud .....	2	1-5
	642267		Adapter Assy., Vacuum Pump .....	1	3-
	630403		Gear, Vacuum Pump Drive .....	1	8-13
	2474		Washer .....	2	12-2
	630979-7		O-Ring .....	2	12-3
	633507		Ignition Assembly, Magneto & Harness .....	1	16-
	630535		Washer, Magneto Hold .....	4	16-2
	A50352A1		Sump Assembly, Oil .....	1	19-
	A50352		. Sump .....	1	19-1
	633233-19		. Rod & Cap Assembly, Oil Gage .....	1	19-2



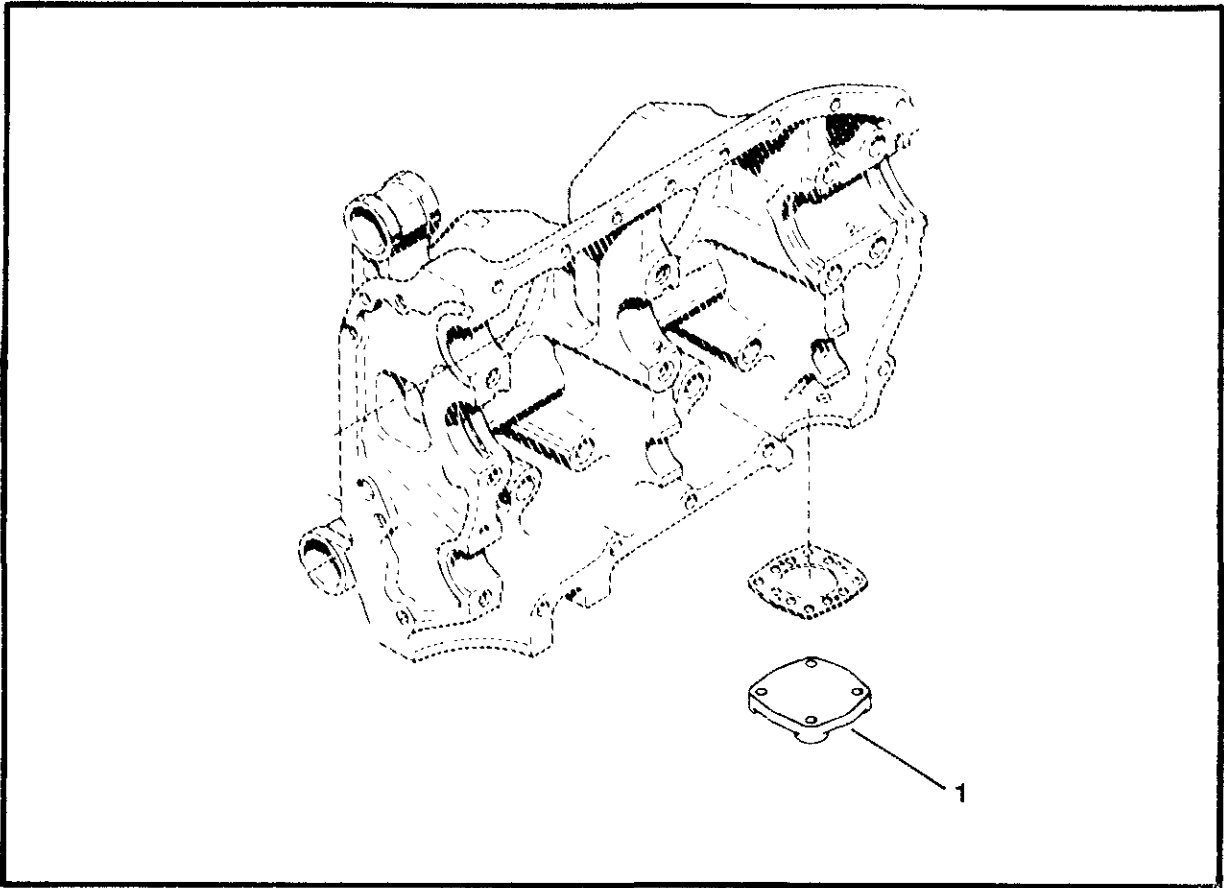

FIGURE 23. COVER, VACUUM PUMP PAD

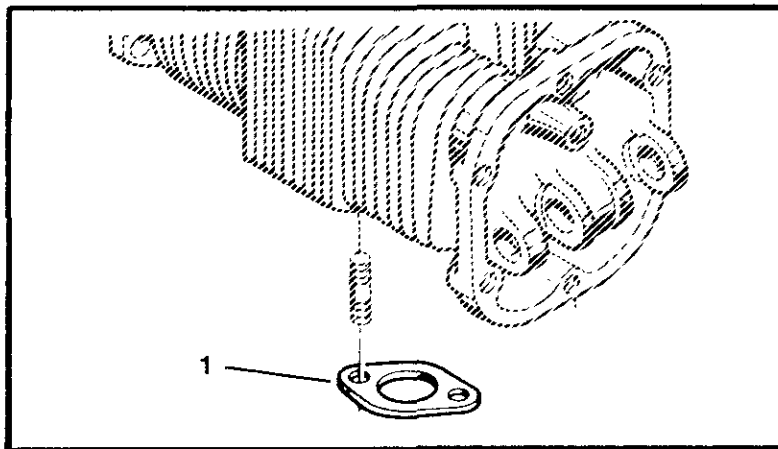

FIGURE 24. FLANGE, EXHAUST

