

August 11, 1992  
12 High Point Drive  
Poughkeepsie, N.Y. 12603

Wicks Aircraft Supply  
410 Pine Street  
Highland, Illinois 62249

Dear Don,

We talked on the phone about the having the spar stock that I have on order planed on the butt ends to accomodate the 1/16 plywood reinforcements that must be installed. I understand that there will be an additional fee. I have ordered the following spar material surfaced on 4 sides and conforming to the mil. spec. S-6073 since these will be installed on a certificated aircraft:

1 piece 4-7/16" x 5/8" x 195" sitka spruce  
2 pieces 5-15/16" x 3/4" x 195" sitka spruce

All dimensions except 195" have a tolerance of + 1/32" and - 0". I ordered 195" lengths which are the required spar length. Perhaps this was a mistake and I should have ordered 196" lengths. Please change my order to 196" lengths.

I have enclosed sketches to illustrate the planing that I am requesting. Please call me collect when you review the sketches so we can discuss them. My number is 914-473-0713. It is my home number so call after 5:00 pm EST or call collect and leave a message with my wife for me to call you. Thanks for your help and consideration.

Sincerely,



David L. Rude

THIS END MUST BE IN FINISHED  
CONDITION

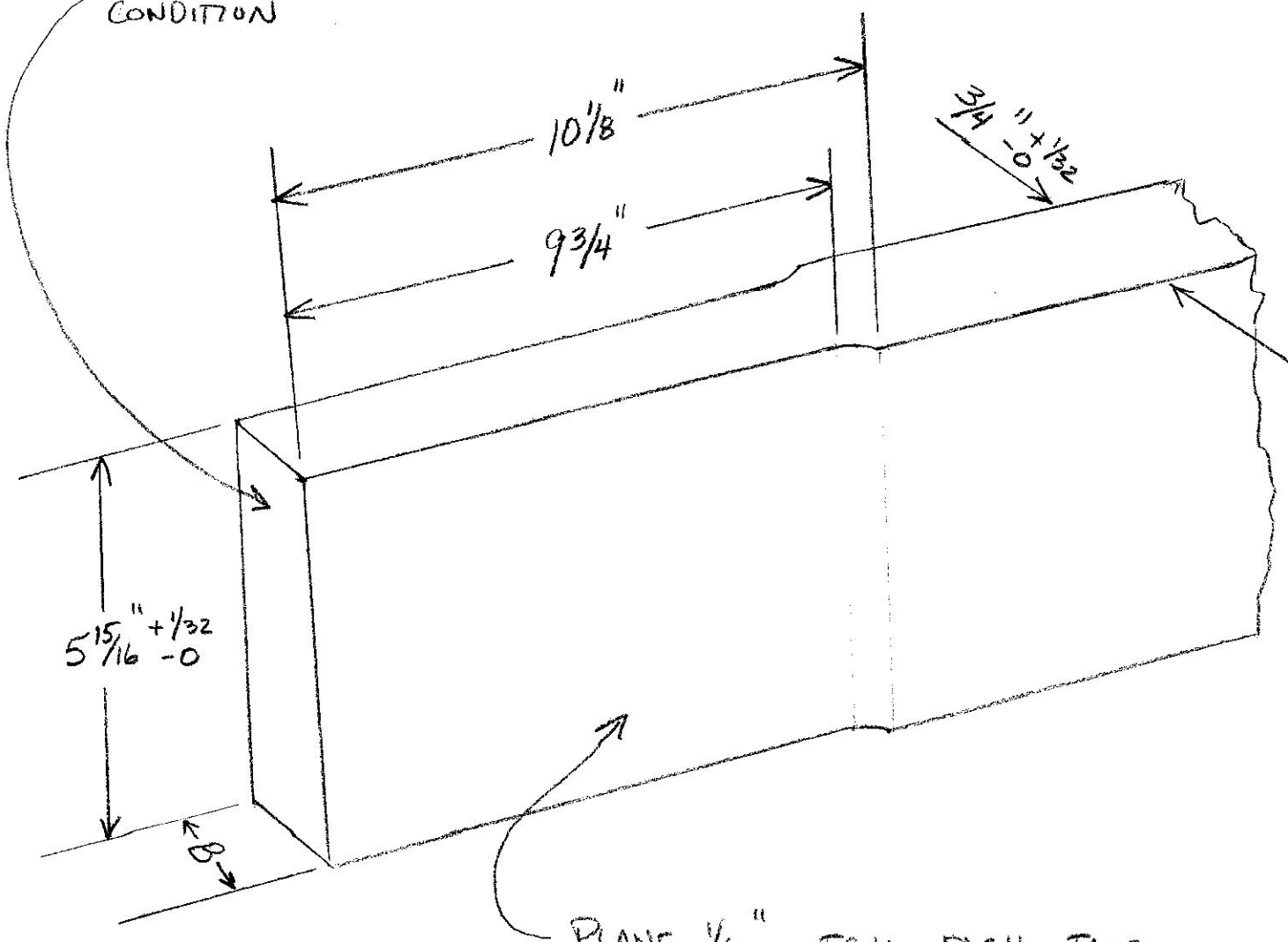

PLANE  $\frac{1}{16}$ " FROM EACH FACE,  
DIMENSION "B" IS  $\frac{5}{8}$ "  $+\frac{1}{64}$ "  
-0

SKETCH FOR  $\frac{3}{4}$ " SPAR BUTT  
PLANING FOR DAVID RUDE

---

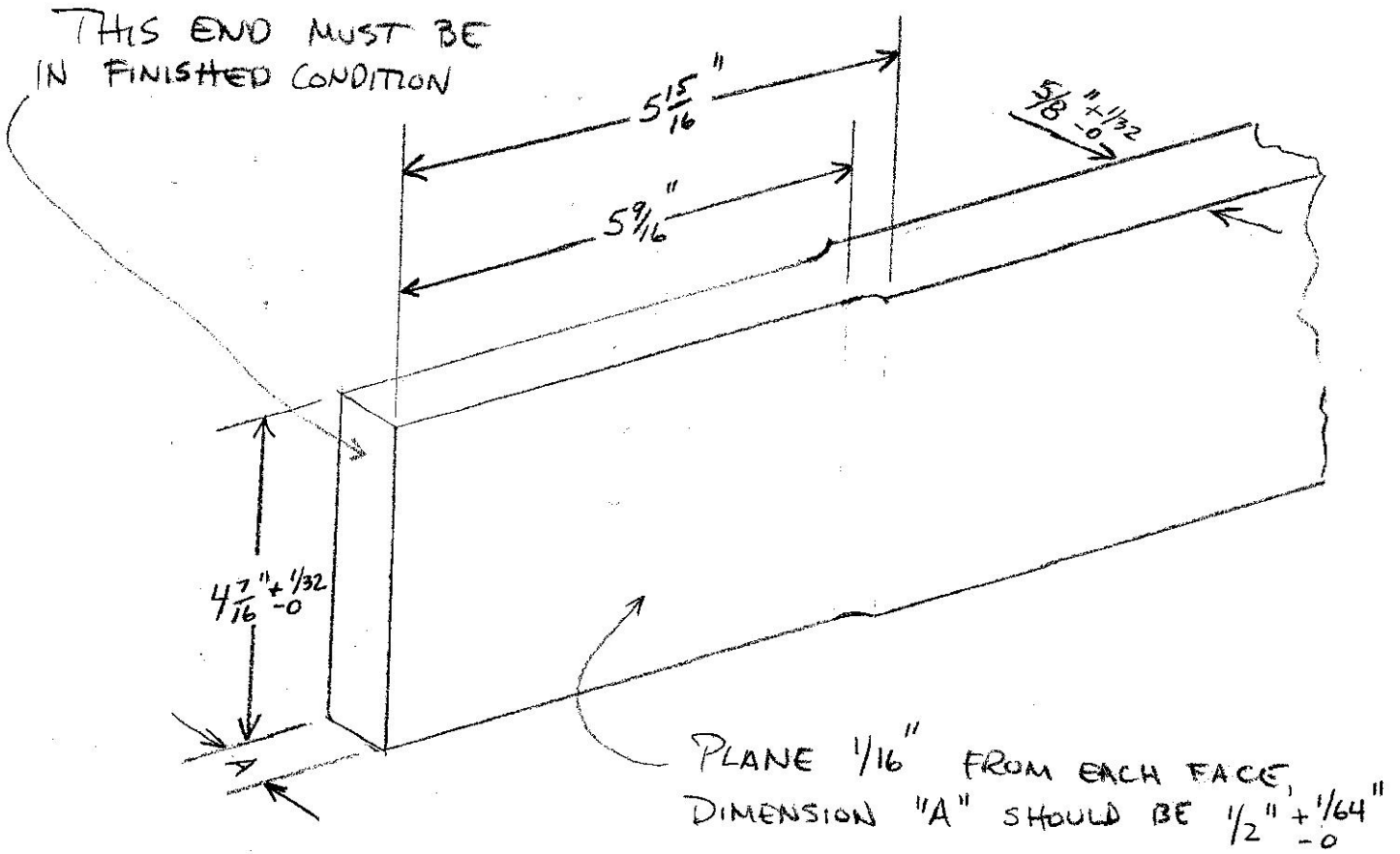

SKETCH FOR  $5\frac{1}{8}$ " SPAR BUTT  
 PLANING FOR DAVID RUDE

---