



76-100 Series Stainless Steel Ball Valve

Threaded, 1/4" to 1" 2000 psig WOG, 1-1/4" to 2" 1500 psig WOG, 2-1/2" to 3" 1000 psig WOG. (See referenced P/T chart)
Cold Non-Shock. 150 psig Saturated Steam, Vacuum Service to 29 inches Hg.
Federal Specification: WW-V-35C, Type: II, Composition: SS, Style: 3.
MSS SP-110; Ball Valves Threaded, Socket-Welding, Solder Joint, Grooved and Flared Ends.

FEATURES

- Investment cast components
- RPTFE seats and stuffing box ring
- Mounting pad for easy actuator mounting
- Blow-out-proof stem design
- Adjustable packing gland
- Meets NACE MR-01-75
- SS lever and nut
- (-24) 1/4" to 2" Certified to API 607, 4th Edition, Class 600 burn

STANDARD MATERIAL LIST

1. Lever and grip	304 SS w/vinyl	7. Gland nut	A276-316
2. Stem packing	RPTFE	8. Stem	A276-316
3. Stem bearing	RPTFE	9. Lever nut	18-8 SS
4. Ball	A276-316	10. Body seal	PTFE
5. Seat (2)	RPTFE	(1-1/4" to 3")	
6. Retainer	A276-316 (1/4" to 1")	11. Body	A351-CF8M
	A351-CF8M (1-1/4" to 3")		

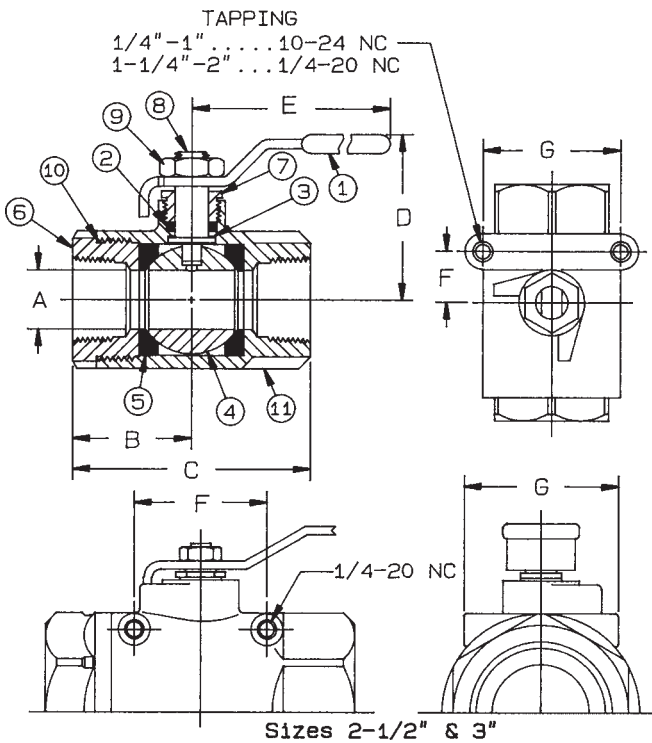

STAINLESS STEEL BALL VALVE

NUMBER	SIZE	A	B	C	D	E	F	G	Wt.
76-101-01	1/4"	.37	1.03	2.06	1.75	3.87	.50	1.12	.58
76-102-01	3/8"	.37	1.03	2.06	1.75	3.87	.50	1.12	.54
76-103-01	1/2"	.50	1.12	2.25	1.81	3.87	.50	1.12	.63
76-104-01	3/4"	.68	1.50	3.00	2.12	4.87	.87	1.37	1.27
76-105-01	1"	.87	1.68	3.37	2.25	4.87	.87	1.37	1.63
76-106-01	1-1/4"	1.00	2.00	4.00	2.62	5.50	.93	1.50	3.06
76-107-01	1-1/2"	1.25	2.18	4.37	3.05	8.00	.93	1.50	4.04
76-108-01	2"	1.50	2.75	5.50	3.24	8.00	.93	1.50	6.05
76-109-01	2-1/2"	2.50	3.37	6.75	4.12	8.00	2.75	3.37	15.57
76-100-01	3"	2.50	3.37	6.75	4.12	8.00	2.75	3.37	16.79

OPTIONS AVAILABLE:

(SUFFIX)	OPTION	SIZES
-02-	Stem Grounded	1/4" to 3"
-03-	1-1/4" CS Stem Extension	1/4" to 3"
-04-	2-1/4" CS Stem Extension	1/4" to 3"
-07-	Steel Tee Handle	1/4" to 2"
-08-	90° Reversed Stem	1/4" to 3"
-14-	Side Vented Ball (Uni-Directional)	1/4" to 2"
-15-	Wheel Handle, Steel	1/4" to 2"
-16-	Chain Lever - Vertical	3/4" to 2"
-19-	Lock Plate	1/4" to 2"
-21-	UHMWPE Trim (Non-PTFE)	1/4" to 3"
-24-	Graphite Packing	1/4" to 3"
-27-	SS Latch-Lock Lever & Nut	1/4" to 3"
-30-	Cam-Lock and Grounded	1/4" to 2"
-32-	SS Tee Handle & Nut	1/4" to 2"
-35-	VTFE Trim	1/4" to 3"
-39-	SS Hi-Rise Locking Wheel Handle, SS Nut	1/4" to 2"
-40-	Cyl-Loc and Grounded	1/4" to 2"
-44-	Seal Welded	1/4" to 2"
-45-	Less Lever & Nut	1/4" to 3"
-46-	Latch Lock Lever - Lock in Closed Position Only	1/4" to 3"
-47-	SS Latch Lock Oval Handle	1/4" to 1"
-48-	SS Oval Handle (No Latch) & Nut	1/4" to 2"
-49-	Assembled Dry	1/4" to 3"
-50-	2-1/4" CS Locking Stem Extension	1/4" to 3"
-57-	Oxygen Cleaned	1/4" to 3"
-58-	Chain Lever - Horizontal	3/4" to 2"
-60-	Static Grounded Ball & Stem	1/4" to 3"
-64-	250# Steam Trim	1/4" to 3"
-P01-	BSPP (Parallel) Thread Connection	1/4" to 3"
-T01-	BSPT (Tapered) Thread Connection	1/4" to 3"

**For Pressure/Temperature Ratings,
Refer to Page M-12, Graph No. 14
(1/4" to 1")
Refer to Page M-11, Graph No. 12
(1-1/4" to 2")
Refer to Page M-10, Graph No. 8
(2-1/2" to 3")**