

- 1) MATL: 6061-T6 OR 3XX STAINLESS STEEL  
.040 TO .063
- 2) FLAT PATTERN GEOMETRY  
4-PLACE DIMENSIONS  
+/- .030
- 3) FIMSH POLISH OUTER SURFACE, EPOXY PRIME INNER SURFACE  
LH, RH OPPOSITE FIMSH

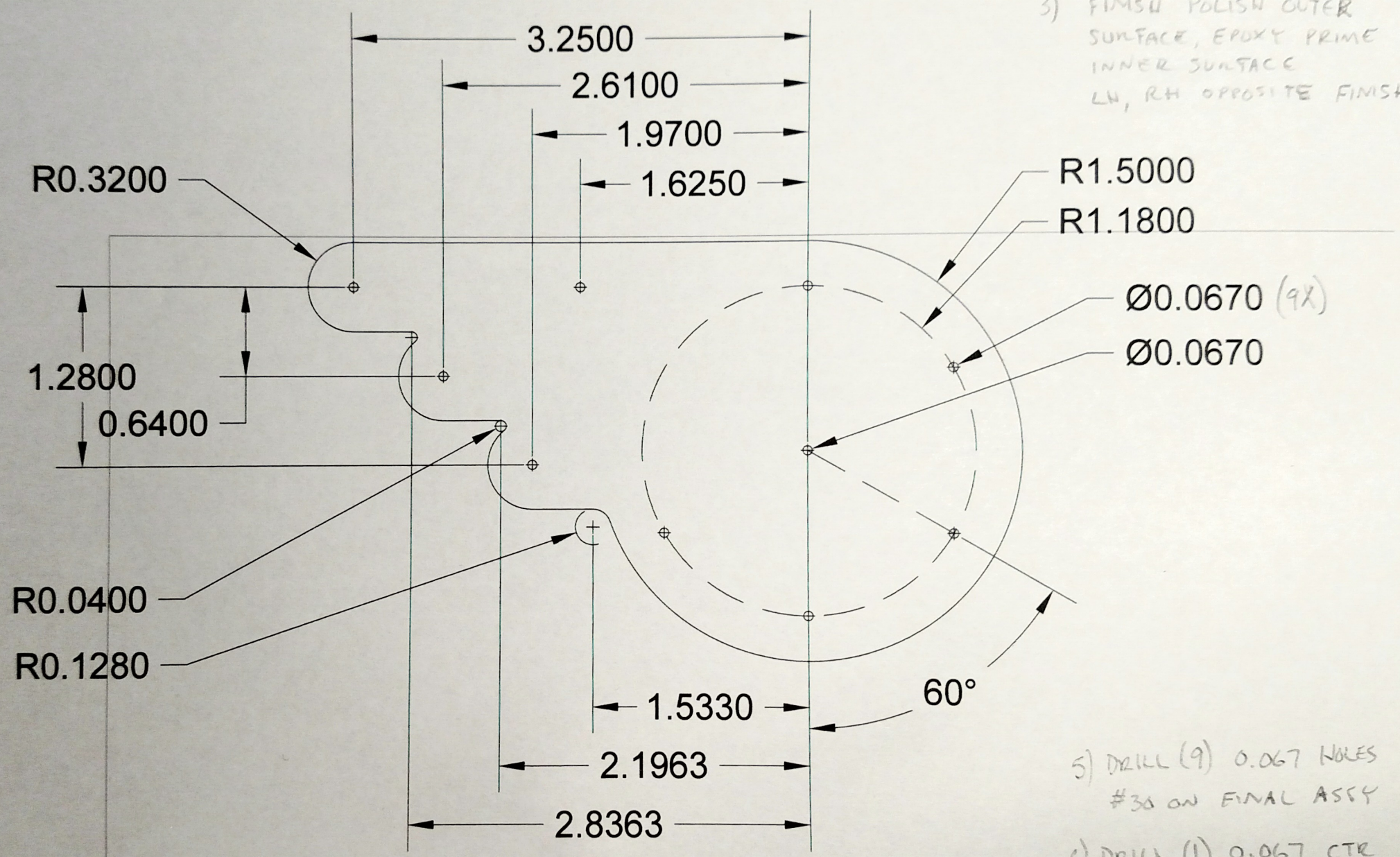

- 5) DRILL (9) 0.067 HOLES  
#30 ON FINAL ASSY
- 6) DRILL (1) 0.067 CTR  
HOLE  $\varnothing 0.266$  ON FINAL  
ASSY