

**CONTINENTAL MOTORS® AIRCRAFT ENGINE**  
**SERVICE INFORMATION LETTER**

**CATEGORY 5**  
**SIL99-2C**

Contains Useful Information Pertaining To Your Aircraft Engine

**Supersedes SIL99-2B**  
**TECHNICAL PORTIONS**  
**FAA APPROVED**

**SUBJECT:** SEALANTS, LUBRICANTS, AND ADHESIVES  
AUTHORIZED BY CMI

**PURPOSE:** Provide current application of sealants, threading, lubricants, and adhesives.

**COMPLIANCE:** During engine installation, maintenance, overhaul or component repair or replacement.

**MODELS**

**AFFECTED:** All CMI engine models operating with AVGAS (gasoline based) fuel.

**I. General Information**

Lubricating oils qualified for use in Continental Motors, Inc. (CMI) gasoline engines are required to meet Society of Automotive Engineers (SAE) specifications.

NOTE: Continental Motors, Inc. listing of accepted SAE J 1899 oils by manufacturer and brand name is provided only for the convenience of our customers. Always refer to the manufacturer's label on the oil to ensure that the oil meets the appropriate SAE specification.

**Major sections within this document:**

	<b>Page</b>
I. General Information	1
II. Oil Change Intervals	3
III. Additives	3
IV. Recommended Sealants, Lubricants, and Adhesives	4
V. Manufacturer/Distributor Supplemental Product Information	10
VI. General Sealant Applications and Threading Procedures (typical)	11

SAE specification J 1899 (formerly MIL-L-22851) is the approval authority for aircraft piston engine ashless-dispersant lubricating oil.

SAE specification J 1966 (formerly MIL-L-6082E) is the approval authority for aircraft piston engine non-dispersant mineral oil.

QPL-J 1899: Qualified Products list is available from:

SAE Headquarters  
400 Commonwealth Drive  
Warrendale, PA 15096-0001

The Naval Air Systems Command is required to maintain QPL-J-1899 and QPL-J-1966.

Naval Air Systems Command  
47123 Buse Road  
Building 2272, Suite 540  
Patuxent River, MD 20670

<b>ISSUED</b>	<b>REVISED</b>		<b>PAGE NO</b>	<b>DOC NO</b>	<b>REVISION</b>
1999/03/29	2014/09/16	P.O. Box 90 Mobile, AL 251-436-8299	1 of 22	<b>SIL99-2</b>	<b>C</b>

Recommended Oil Grade:

- Above 40°F ambient air, sea level SAE 50 or multi-viscosity
  - Below 40°F ambient air, sea level SAE 30 or multi-viscosity
- NOTE: See SIL99-1 (latest version) for preservation information.

The marketers of the aviation lubricating oil listed below (Table 1) have supplied data to Continental Motors, Inc. (CMI) indicating their products conform to all the requirements of CMI Specification MHS-24, Lubricating Oil, Ashless Dispersant.

In listing the product names, CMI makes no claim of verification of marketer's statements or claims. The listing is made alphabetically and is provided only for the convenience of the user.

**Table 1. Qualified SAE J-1899 Ashless Dispersant Engine Oil**

Supplier	Brand
Air BP Lubricants	Castrol Aviator AD Oil
	Castrol Aviator A Oil
ChevronTexaco	ChevronTexaco Aero Oil AD
	ChevronTexaco Aero Oil AD SAE 20W-50
Delta Petroleum Company	Delta Avoil Oil
Exxon Company, USA	Exxon Aviation Oil EE
	Exxon Elite
Gulf Oil Company	Gulfpride Aviation AD
Mobil Oil Company	Mobil Aero Oil
NYCO S.A.	Turbonycoil 3570
Pennzoil Company	Pennzoil Aircraft Engine Oil
Phillips 66	Phillips 66 Type A 100 AD, 120 AD
	Phillips 66 X/C Aviation Oil SAE 20W-50, SAE 25W-60
	Phillips 66 Victory Aviation Oil 100AW
Quaker State Oil & Refining Co.	Quaker State AD Aviation Oil
Red Ram Limited (Canada)	Red Ram X/C Aviation Oil 20W-50
Shell Aviation	Aeroshell Oil, (Mineral) 65, 80, 100, 2F Anti Corrosion Formula
	Aeroshell Multi-grade Oil AD, 15W - 50
	Aeroshell Oil W65, W80, W100
	Aeroshell Oil W80 Plus, W100 Plus Anti Corrosion Formula
Sinclair Oil Company	Sinclair Avoil
Total France	Total Aero DM 15W - 50

**Table 2. Break-in Oil**

Type	Equivalent	Application
MIL-C-6529 Type II Corrosion preventive mineral oil <sup>1</sup>	Fly-away oil	First 25 hours of engine operation or until oil consumption stabilizes
SAE J-1966 Aviation Oil	Non-dispersant mineral oil for piston aircraft engines	

1. Mineral oil conforming to MIL-C-6529 Type II contains a corrosion preventive additive and must not be used for more than 25 hours or six months, whichever occurs first. If oil consumption has not stabilized within this time, drain the mineral oil, replace the oil filter, and replace discarded mineral oil with SAE J-1966 aviation oil.

**Table 3. Preservative Oil**

Type	Equivalent	Application
MIL-P46002	Grade 1 Oil, Non-Rust VCI-105	Temporary or Indefinite Storage
	Motorstor Oil Preservative	

**II. Oil Change Intervals**

Refer to the engine maintenance manual and/or the aircraft manufacturers or Supplemental Type Certificate (STC) holders AFM/POH for fuel specifications, specified oil change intervals and inspection procedures.

Oil change intervals published in this manual are minimum requirements. Continental Motors, Inc. (CMI) believes more frequent oil and filter changes enhance engine service life. CMI recommends engine oil be drained and replenished every 25 hours of operation or 4 months for engines that incorporate an oil screen. Engines with full flow oil filters, either large or small, should have the oil changed every 50 hours or 4 months.

NOTE: When using the small oil filter (4.80 inch high) do not exceed 50 hours and/or 6 months between oil and filter changes. When using the larger oil filter (5.80 inch high) do not exceed 100 hours and/or 6 months between oil and filter changes. Oil screens and oil filter elements must be inspected for contaminants at each oil change. Oil analysis may be used in addition to the oil screen or filter element inspection, but not as a replacement for it.

**III. Additives**

We often receive inquiries regarding the potential use of alternative fuel and oil additives and/or concentrates (formulated primarily for automotive and industrial engine applications) for use in our aircraft engines. Most of these additives and concentrates are not compatible with air-cooled, light aircraft engines in their operating environments. With the exception of the use of isopropyl alcohol or diethylene glycol monomethyl ether (DiEGME) compound (described in the following paragraph), we do not recommend the use of additives or concentrates in any of our aircraft engines. The use of unapproved additives may void the engine warranty. Use only recommended fuels and lubricants.

**WARNING**

**Mixing of DiEGME compound with fuel concentration in excess of the recommended (0.15% volume maximum) could have a harmful effect on engine components. Use only the manufacturer’s recommended blending equipment and procedures to achieve proper proportioning.**

Under certain ambient conditions of temperature and humidity, sufficient quantities of water may exist in the fuel to create restrictive ice formation in the fuel supply. To alleviate this occurrence, it is permitted to add no more than 3% (by volume) isopropyl alcohol to the fuel supply. Also, DiEGME conforming to military specification MIL-DTL-85470B, if approved by the aircraft manufacturer, may be added for this purpose. DiEGME compound must be carefully mixed with the fuel in concentrations not to exceed 0.15% (by volume).

<b>ISSUED</b>	<b>REVISED</b>	 P.O. Box 90 Mobile, AL 251-436-8299	<b>PAGE NO</b>	<b>DOC NO</b>	<b>REVISION</b>
1999/03/29	2014/09/16		3 of 22	SIL99-2	C

#### IV. Recommended Sealants, Lubricants, and Adhesives

**Table 4. Sealants**

Item	P/N	Type	Application	Remarks
1	642188	CRC Copper Coat 401504 Gasket Sealant	Non-beaded gaskets; Apply both sides of starter gasket, oil cooler adapter gasket, vacuum pump adapter gasket, and fuel pump pad cover gasket. Beaded gasket; Apply to non-beaded side of starter gasket, oil cooler adapter gasket, vacuum pump adapter gasket, and fuel pump pad cover gasket.	0200D, X
			All press type plugs (Hubbard etc.)	All models
			Intake manifold gasket	
			ACC case to crankcase (crankcase side only)	C-90, O200, IO240, O300, IO360, LTSIO360, TSIO360
			Oil drain back tubes	C-90, O200, O300
			Oil cooler (both sides)	IO360, LTSIO360, TSIO360
			Oil seal accessory drive (O.D. only)	IO360, LTSIO360, TSIO360
			2 bolt suction tube gasket (both sides)	470, 520 and 550 (where applicable)
			Gasket and oil filler neck holes	470, 520, 550 (Sandcast), and GTSIO520
			Cam bore cover gasket (except beaded gasket)	470, 520, 550, GTSIO520, IO240
			Idler pin gasket	470, 520, 550, GTSIO520
			In parting line area of 3-way joints	Sump to crankcase or sump to crankcase to accessory case
			All gaskets (both sides) except magneto gasket and gaskets between intake manifold and cylinder head.	Tiara 6-285, 6-230
			Oil seal at alternator drive (O.D. only)	
2	646940	F/I Sealant Loctite 569 Hydraulic Sealant	All pipe thread fittings in fuel injection system (except pipe plug threads in throttle body units)	See Figure 2
3	646942	Gasket Maker Loctite 515 Gasket Eliminator Flange Sealant	Crankcase parting face	Where applicable
			Engine nose seal, scavenge oil pump covers, between crankcase and sump gasket, oil pump covers	All models, where applicable
			Between starter adapter gasket & crankcase	All Permold crankcase models
			Between oil sump and sump gasket	Non-beaded gaskets only
			642910 oil seal, O.D. of all uncoated oil seals, except fuel pump adapter seal	All models, where applicable
4	649246	Loctite 290 Sealant	Data plate screw installation on throttle bodies	All models, where applicable
5	653692	Loctite LocQuic Primer 7649	Crankshaft nose oil seal area	All models

**Table 4. Sealants**

Item	P/N	Type	Application	Remarks
6	654663	Loctite 1522029 Gasket Sealant (with P/N 641543 Silk Thread)	Crankcase parting face	Apply according to assembly instructions
			Starter adapter to accessory case	
			Accessory drive adapter	
			Pressure oil pump covers Pressure scavenge pump covers	
7	657042	Loctite 565 Adhesive Sealant	Use on all pipe threads to oil coolers and other oil sources	All models (use sparingly on male threads only)
8	N/A	Miller-Stephenson MS-122AD	Ignition harness terminals at magneto block end & spark plug / ECU terminals	All models
9	N/A	Loctite 592 Teflon PS/T Pipe Sealant	Use on all pipe threads except as noted elsewhere All pressure relief valve housing threads Permold 2 studs engine mount 1-3-5 side bottom	All models, where applicable
			All threaded fasteners installed in a stud hole through to an oil source	Apply before installing threaded fastener

**Table 5. Lubricants**

Item	P/N	Type	Application	Remarks
1	646943	Loctite 76732 Anti-Seize Lubricant	Fuel injector nozzles (at cylinder head)	See Figure 2
			Mechanical tachometer drive housing threads not connected through to an oil source.	At engine assembly
			Exhaust studs (applied to nut end before torque), exhaust slip joints	
			Vernatherm plug	
			All 0.3125 and larger studs unless otherwise noted	
			Throttle body air reference fittings	Where applicable
			Oil sump return fitting	IO360ES3B & IO360HB9B
2	654468	Shell #5 MIL-G-3545-C Grease (optional Lubriplate 630 AA or LPS 2)	Fuel injection linkages	At engine assembly
			Throttle & mixture control linkages	Apply at pivot points during assembly and periodic maintenance
3	654514	CRC 336 Rust Preventative Compound	Spray exhaust end of turbocharger	After engine test
4	654561	Shell Alvania # 2	Light coat at contact point between nut seat and ignition lead ferrule	All models, where applicable
			Apply to oil seal lip only (alternator seal)	LTSIO360E, EB, RB; TSIO360E, EB, F, FB, GB, KB, LB

**Table 5. Lubricants**

Item	P/N	Type	Application	Remarks
5	656817	Super Molyshield Grease	Starter worm gear & bevel gear teeth	All models during engine assembly
			Needle bearings and ball bearings	
			Valve stems	
			Accessory drive splines and couplings	Where applicable
			Idler gear and pin	470, 520, 550
			Magneto rubber drive bushings	All models
			Oil seal lips only	
			Fuel injection controls, o-rings, springs, shafts, and bushings	Except 360, TSIO520D, GTSIO520K, which use 50W motor oil
			Oil pumps (pressure & scavenge)	Coat gear cavity during pump assembly
			Adapter (tach reduction)	TSIO & LTSIO360
6	N/A	Use only manufacturer's recommended spark plug thread lubricant	Spark plugs	All models
7	N/A	Chesterton #995 Release Agent or WD-40	Induction system hoses and flex duct connections, pipe plugs in throttle body units	All models
8	N/A	Dow Corning No. 4	Rubber oil seal of spin-on oil filters	All models where applicable
			Governor pad gaskets (both sides)	
			Starter adapter cover o-rings	
9	N/A	Dow Corning G-N Paste	Camshaft lobes and tappet faces	During engine assembly
10	N/A	Lubriplate 930 AA	O.D. of valve guides	All models during valve guide installation

**Table 5. Lubricants**

Item	P/N	Type	Application	Remarks
11	N/A	SAE J-1966 Grade 50 MHS-27 Aviation Oil	Quill Shaft Springs	GTSIO520
			Crankshaft bearings	During engine assembly
			Connecting rod bearings	
			Prop driver, driven gears & bearings	
			Camshaft bearings	
			Tachometer gears & adapters	
			Accessory spur gear teeth	
			Prop governor transfer collar & sleeve	
			Starter cone, bushing & nut	
			Starter clutch spring (ID & OD)	
			Pistons, piston pins, & piston rings	
			Thrust washers	
			Oil filter adapter seals	
			O-rings	
			Carburetor fuel connections	Carburetor-equipped models
			Valve guide seals	Apply to sealing surface
V.T.C. unit pistons & centrifugal valves, rocker arms, valves and tappets	Tiara 6-285, 6-230			
Cylinder studs, through bolts, crankcase studs, connecting rod bolts and nuts; and engine accessory studs unless installed in blind or stud holes not through to an oil supply or otherwise specified	Lubricate bolt thread and nut seat before tightening nuts			

**Table 6. Adhesives**

Item	P/N	Type	Application	Remarks
1	646941	Loctite 271 High Strength Adhesive Sealant (used with P/N 653693 Loctite 7471 Primer)	Cylinder deck studs	Breakaway torque minimum 100 in-lbs. after two hours
			Crankcase breather tubes	470 & 520 (Sandcast) & GTSIO520
			Crankcase nose seal retainer bolts	All models
			Intake manifold mount studs	C-75, C-85, C-90 & O-200
			Mechanical tachometer drive studs trough to an oil source	where applicable
			Oil gauge rod housing to crankcase	IO360, LTSIO360, TSIO360, O470, IO470, TSIO470, IO520A, B, E, G, J, K, L, IO550D, E, F, TSIO520A, AE, AF, C, CE, G, H, M, P, R, T
			Oil pump gear mounting pin in accessory cover	IO360, LTSIO360, TSIO360
			Press fit breather and oil fill necks	IO240, IO360, LTSIO360, TSIO360
			Rocker cover studs, rocker arm pivot studs, push rod retainer stud	Tiara 6-285, 6-230
			Timing indicator pin	GTSIO-520
			Top accessory drive gear (breather slinger) bolts	Tiara 6-285, 6-230
			V.T.C. unit bushing retainer screws	
			V.T.C. unit housing to crankshaft	
2	649306 (optional 646940)	Loctite 222 Sealant (or optional Loctite Hydraulic Sealant 569)	Diverter valve assembly (bracket to valve)	TSIO360MB, SB IO360ES2B
			Manifold valve to bracket screws	All models
			Coolant pump impeller ring screws	All liquid cooled models
			Studs 0.25 diameter and smaller	All models
			Manifold valve assembly data plate screws	All models
			Mag stud holes and stud holes through an oil source on accessory end of crankcase	O200, IO240, O300, IO360, LTSIO360, TSIO360, 470, 520, 550 (apply when installing studs)
			All pipe thread fittings in fuel injection system except pipe plug threads in throttle body unit	All models
3	649366	Loctite 242	Magneto housing pressurization fitting	All models, where applicable
4	652983	Loctite 620 Adhesive Sealant	Coolant pump mechanical seal, standard repair on starter adapter bearing bore	All liquid cooled models
5	654495	Loctite 8531 Adhesive Sealant	Starter clutch assembly bearing	O200, O300, IO240
6	654562	Loctite 609 Adhesive / Sealant	Bearing OD installed on starter clutch assembly	O200A, B, IO240A, B, O300A
7	655515	Adhesive Sealant (RTV)	Alternator assembly	GIO550, GTSIO520, IO520, IO550, IOF550, TSIOL550, TSIOF550



**Table 6. Adhesives**

Item	P/N	Type	Application	Remarks
8	655700	PBC30 Adhesive	Inter-cylinder baffles	IO360, TSIO360, LTSI360, TSIO520, IO550, IOF550, TSIO550 and TSIOF550
9	800126	3M Super 77 Adhesive	EMI Gasket	All FADEC (apply to gasket before installing on ECU)
10	658493	3M Scotch-Weld 1300 Adhesive	Induction manifolds, diverter valve bracket	IO360AF, ES; TSIO360MB, RB; LTSIO360RB; TSIO520BE; IO550G, N, P, R; IOF550 ; TSIO550A, B, C, E, G, K, N; TSIOF550

**Table 7. Miscellaneous**

Item	P/N	Type	Application	Remarks
1	535011	Safety wire -.032 in dia. Steel Corrosion Resistant	Where safety wire is required	N/A
2	800154	Safety wire -.020 in dia. Steel Corrosion Resistant	Where safety wire is required	FADEC electronic control units
3	626531-1	Enamel - Gold (1 qt)	High temperature paint for cosmetic and corrosion protection	N/A
4	626531-2	Enamel - Gold (1 gal)		
5	N/A	"ACCELAGOLD" Turco Products	Corrosion protection interior and exterior aluminum parts	N/A

<b>ISSUED</b>	<b>REVISED</b>	 P.O. Box 90 Mobile, AL 251-436-8299	<b>PAGE NO</b>	<b>DOC NO</b>	<b>REVISION</b>
1999/03/29	2014/09/16		9 of 22	SIL99-2	C

## V. Manufacturer/Distributor Supplemental Product Information

Table 8. Supplemental Product Information

<b>Manufacturer/Distributor</b> <i>Recommended Products</i>	<b>Address</b>	<b>Phone</b>	<b>FAX</b>	<b><sup>1</sup>Web Address</b> <b>(http://www.)</b>
<b>American Lubricants / Moly Motor Oil</b> <i>Super Molyshield</i>	1227 Deeds Dayton, OH 45401	937-222-2851	618-534-5231	molymotoroil.com
<b>A.W Chesterton Company</b> <i>Chesterton #995 Release Agent</i>	500 Unicorn Park Drive Woburn, MA 01801-3345	800-835-4135 781-438-7000	781-438-8971	chesterton.com
<b>CRC Industries/Chemical Products</b> <i>336 Rust Preventative Compound Copper Coat 401504 Gasket Sealant</i>	885 Louis Drive Warminster, PA 18974	800-272-4620 800-556-5074	800-272-4560 215-674-2196	crcindustries.com
<b>Daubert Chemical</b> <i>MIL-P-46002A Grade 1 Oil Non-Rust VCI-105</i>	4700 South Central Ave Chicago, IL 60638	708-563-8325	708-496-7367	daubertchemical.com
<b>Dow Corning Corporation</b> <i>Dow Corning No. 4 Dow Corning G-N Paste</i>	P.O. Box 994 South Saginaw Road Midland, MI 48686	989-496-4400 800-662-0661	989-496-7879	dowcorning.com
<b>Graham Aircraft Engines</b> <i>Motorstor Oil</i>	PO Box 3214 Peachtree City, GA 30269	770-252-4995	770-252-5270	highaero.com
<b>Henkel Aerospace</b> <i>ACCELAGOLD Turco Products</i>	32100 Stephenson Hwy Madison Heights, MI 48071	248-583-9300	248-583-2976	henkel.com
<b>Loctite Industrial Products</b> <i>Loctite 76732 Loctite 565 Adhesive Sealant Loctite 569 Hydraulic Sealant Loctite 515 Gasket Eliminator Loctite 290 LocQuic Primer 7649 Loctite 1522029 Gasket Sealant Loctite 592 Teflon PS/T Pipe Sealant Loctite 222 Sealant Loctite 271 HS Loctite 242</i>	1001 Trout Brook Crossing Rocky Hill, CT 06067-3910	860-571-5100 800-243-4874	860-571-5465	loctite.com
<b>Lubriplate</b> <i>Lubriplate 930 AA</i>	129 Lockwood St. Newark, NJ 07105	973-589-9150 800-733-4755	973-589-4432	lubriplate.com
<b>Miller-Stephenson Chemical Co.</b> <i>MS-122AD (10400533)</i>	6348 Oakton St Morton Grove, IL 60053	847-966-2022 800-992-2424	847-966-8468	miller-stephenson.com
<b>Shell Oil Company</b> <i>Shell #5 Shell Alvania #2</i>	P.O. Box 2463 Houston, TX 77252	713-241-4819 800-332-6457	713-241-6511	shell-lubricants.com

1. Unless otherwise indicated, type <http://www.> followed by the Web Address. shown

<b>ISSUED</b>	<b>REVISED</b>	 P.O. Box 90 Mobile, AL 251-436-8299	<b>PAGE NO</b>	<b>DOC NO</b>	<b>REVISION</b>
1999/03/29	2014/09/16		10 of 22	SIL99-2	C

## VI. General Sealant Applications and Threading Procedures (typical)

*CAUTION: Never use Teflon tape on fluid fittings or fuel nozzles. Only apply sealants or lubricants to fitting tapered ends up to the first two threads. Never apply to the first two threads to prevent contaminating fuel supply.*

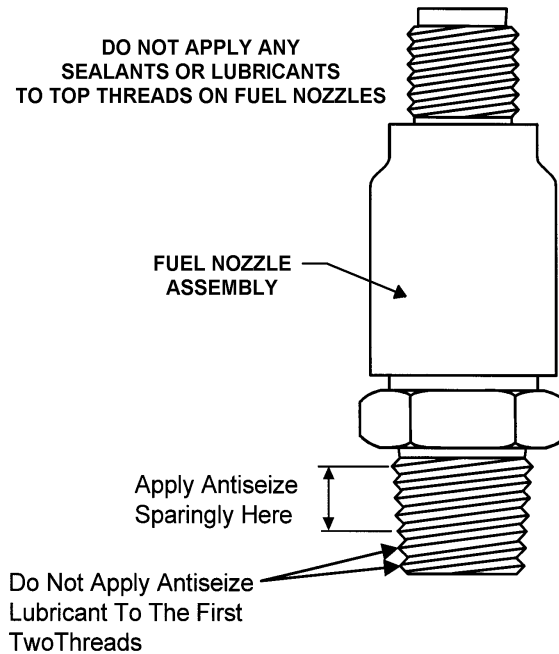

**Figure 1. General Anti-Seize Lubricant Application**

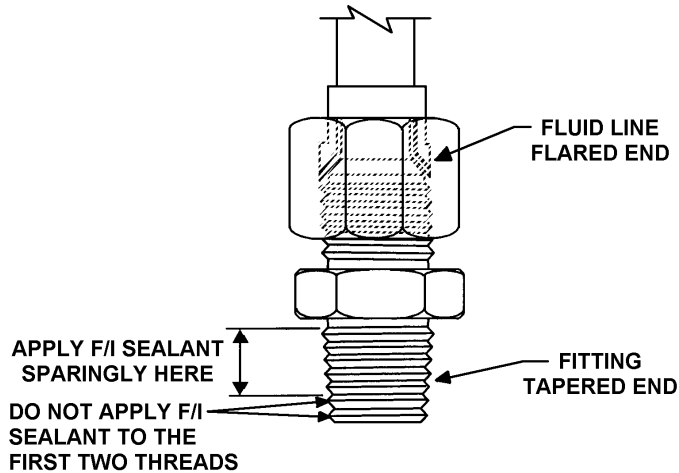

**Figure 2. General Fuel Injection Sealant Application**

ISSUED	REVISED	 P.O. Box 90 Mobile, AL 251-436-8299	PAGE NO	DOC NO	REVISION
1999/03/29	2014/09/16			11 of 22	SIL99-2

## A. Crankcase Sealant and Threading Procedure for Four Cylinder Engines

1. Use full strength, non-thinned P/N 654663 (gasket sealant). Shake or mix well before using.

*CAUTION: Apply gasket sealant and threading (a continuous, single piece) only as illustrated.*

2. Apply P/N 654663 (gasket sealant) to 2-4 case half. Apply gasket sealant per the manufacturer's instructions only in areas where threading is indicated. When applying, use short light brush strokes until an even thin coat is obtained. The gasket sealant should be viscous enough that most of the brush marks disappear; if not, remove old gasket sealant and reapply with new gasket sealant.

NOTE: Allow the gasket sealant to air dry to a tacky condition before applying silk threading. Do not apply gasket sealant to crankshaft nose seal area.

3. Apply a thin translucent coat of P/N 654942 (gasket maker), not to exceed 0.010 inch thick, to the 1-3 case half. Apply gasket maker in all areas that will mate against areas where gasket sealant was applied on the matching 2-4 case half (except the through bolt bosses).
4. Apply and position P/N 641543 (a continuous, single piece of grade "D" silk thread) on the 2-4 case half as specified (see Figures 3 and 4, page 13). Ensure the free ends of your thread are covered by gaskets (except at the nose oil seal).
5. Clean crankcase crankshaft front oil seal land with P/N 653692 (LocQuic Primer "N") and apply an even coat of P/N 654942 (gasket maker).
6. Assemble crankcase halves; install and torque all crankcase hardware in proper sequence in accordance with the applicable overhaul manual as soon as possible.

NOTE: Take care to prevent displacement or damage to the crankshaft oil seal and silk thread. Insure thrust washer halves and bearing halves remain in place.

ISSUED	REVISED		PAGE NO	DOC NO	REVISION
1999/03/29	2014/09/16	P.O. Box 90 Mobile, AL 251-436-8299	12 of 22	SIL99-2	C

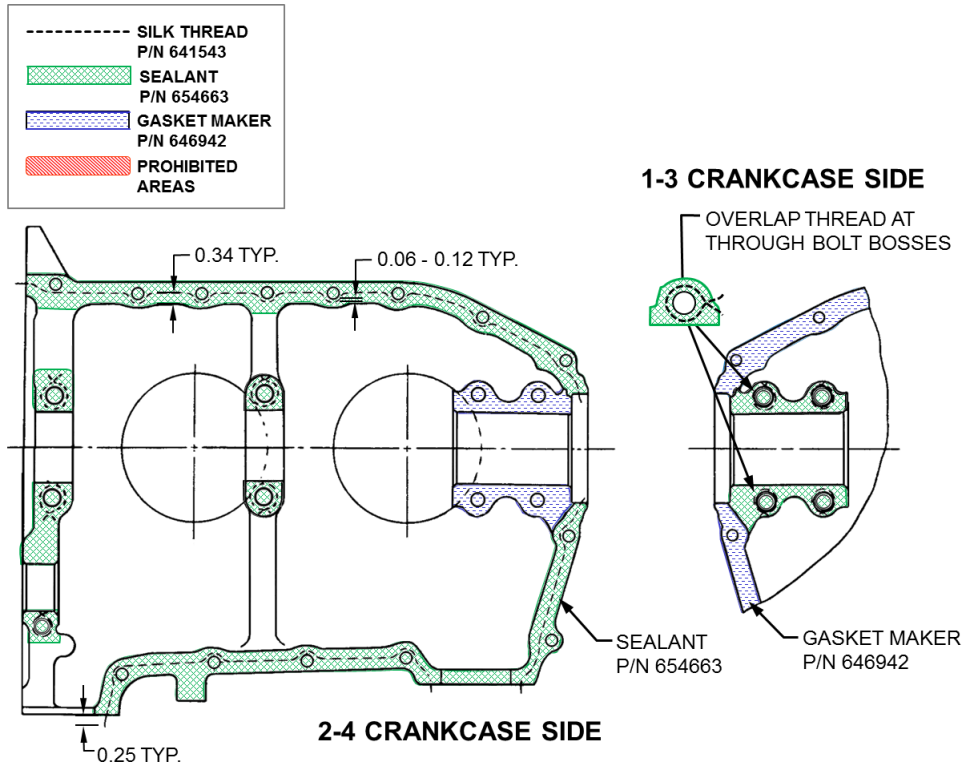

Figure 3. Threading Diagram, C75, C85, C90, O200 Crankcase

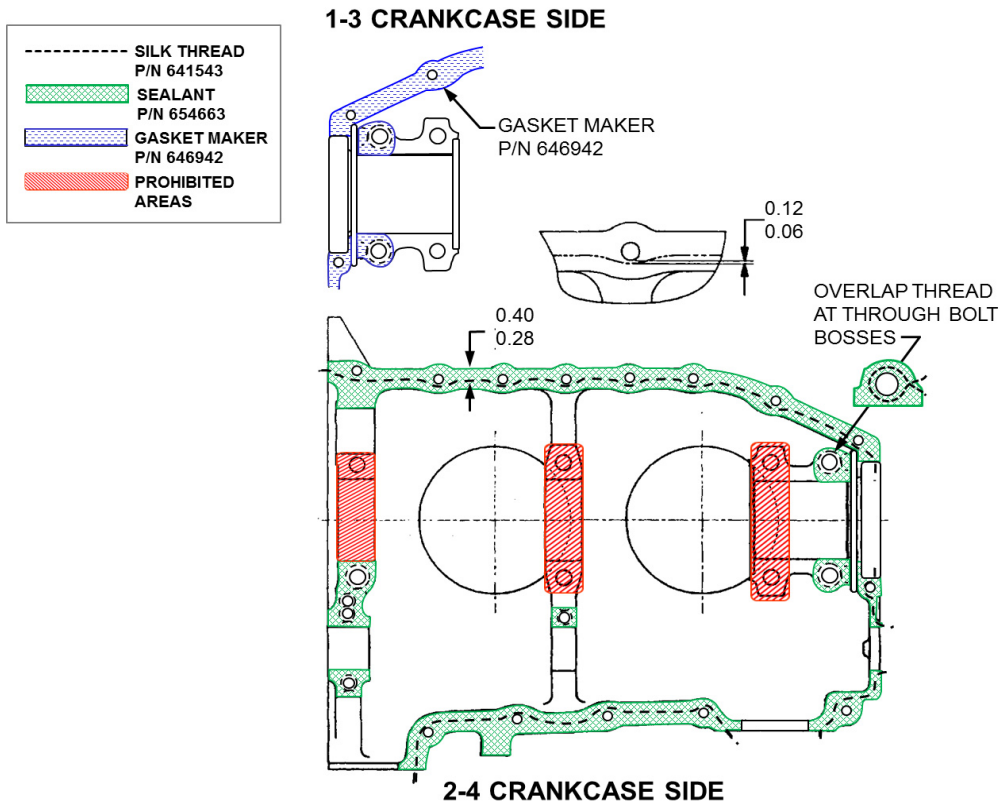

Figure 4. Threading Diagram, 240, IO240 Crankcase

ISSUED	REVISED	 P.O. Box 90 Mobile, AL 251-436-8299	PAGE NO	DOC NO	REVISION
1999/03/29	2014/09/16		13 of 22	SIL99-2	C

## B. Crankcase Sealant and Threading Procedure for Six Cylinder Engines

1. Use full strength, non-thinned P/N 654663 (gasket sealant). Shake or mix well before using.

*CAUTION: Apply gasket sealant and threading (a continuous, single piece) only as illustrated.*

2. Apply P/N 654663 (gasket sealant) to 2-4-6 case half. Apply gasket sealant per the manufacturer's instructions only in areas where threading is indicated. When applying, use short light brush strokes until an even thin coat is obtained. The gasket sealant should be viscous enough that most of the brush marks disappear; if not, remove old gasket sealant and reapply with new gasket sealant.

NOTE: Allow the gasket sealant to air dry to a tacky condition before applying silk threading. Do not apply gasket sealant to crankshaft nose seal area.

3. Apply a thin translucent coat of P/N 654942 (gasket maker), not to exceed 0.010 inch thick, to the 1-3-5 case half. Apply gasket maker in all areas that will mate against areas where gasket sealant was applied on the matching 2-4-6 case half (except the through bolt bosses).
4. Apply and position P/N 641543 (a continuous, single piece of grade "D" silk thread) on the 2-4-6 case half as specified (see Figures 5 through 8, pages 15-16). Ensure the free ends of your thread are covered by gaskets (except at the nose oil seal).
5. Clean crankcase crankshaft front oil seal land with P/N 653692 (LocQuic Primer "N") and apply an even coat of P/N 654942 (gasket maker).
6. Assemble crankcase halves; install and torque all crankcase hardware in proper sequence in accordance with the applicable overhaul manual as soon as possible.

NOTE: Take care to prevent displacement or damage to the crankshaft oil seal and silk thread. Insure thrust washer halves and bearing halves remain in place.

ISSUED	REVISED		PAGE NO	DOC NO	REVISION
1999/03/29	2014/09/16	P.O. Box 90 Mobile, AL 251-436-8299	14 of 22	SIL99-2	C

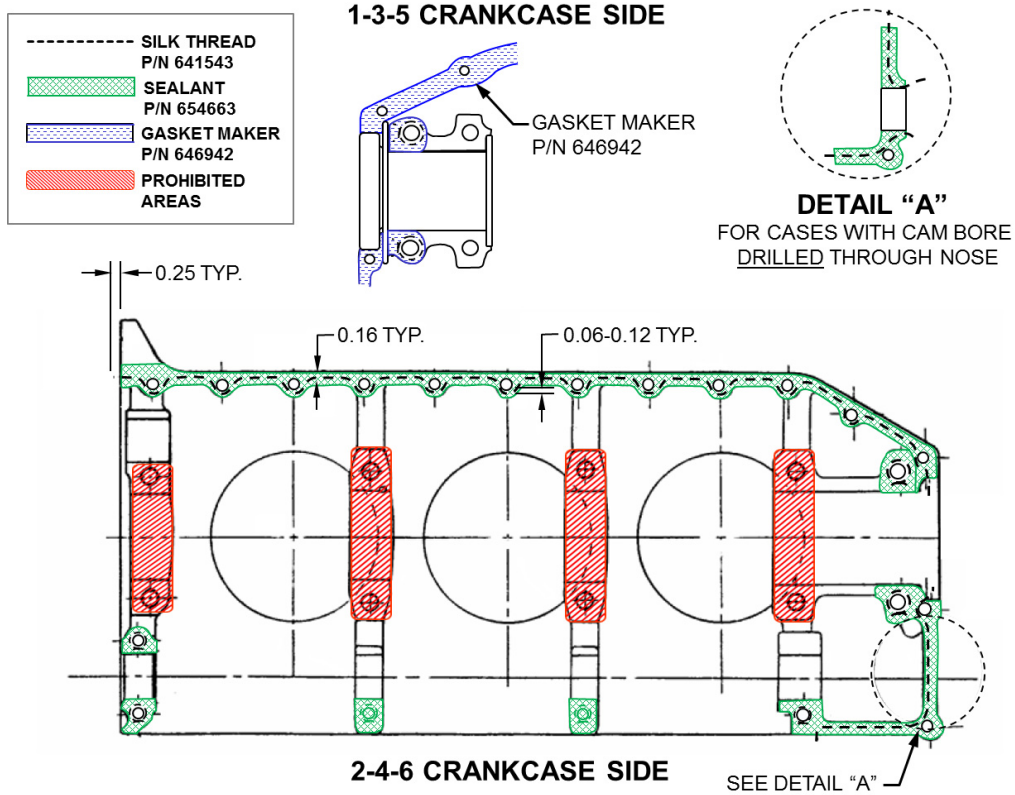

Figure 5. Threading Diagram, IO360, LTSIO360 Crankcase

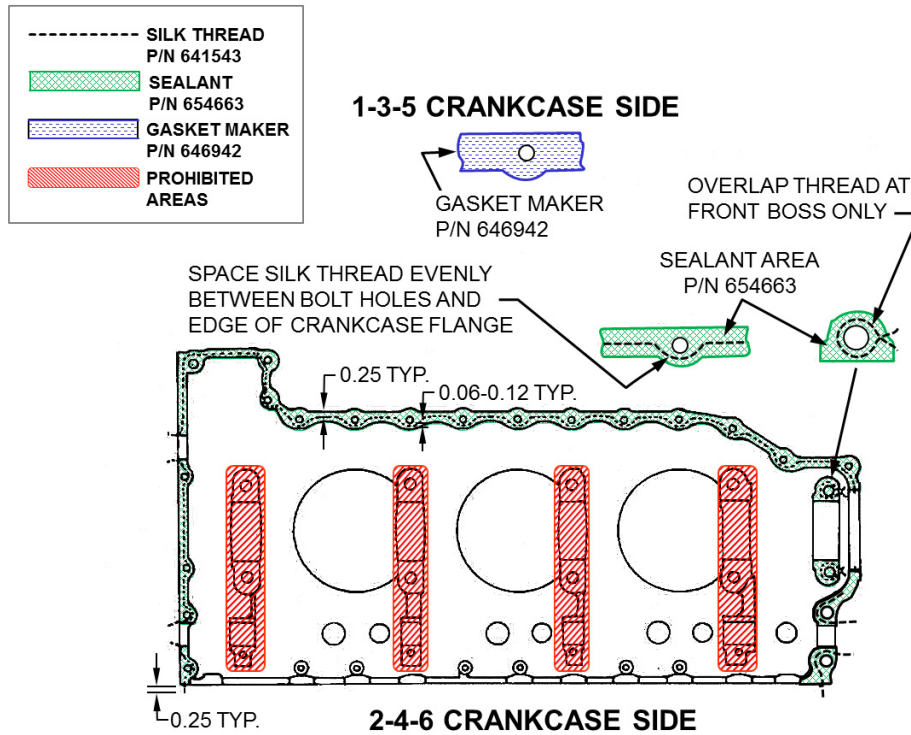

Figure 6. Threading Diagram, IO520, TSI0520, IO550, IOF550, TSI0550, TSIOL550 Permold Crankcase

ISSUED	REVISED	 P.O. Box 90 Mobile, AL 251-436-8299	PAGE NO	DOC NO	REVISION
1999/03/29	2014/09/16		15 of 22	SIL99-2	C

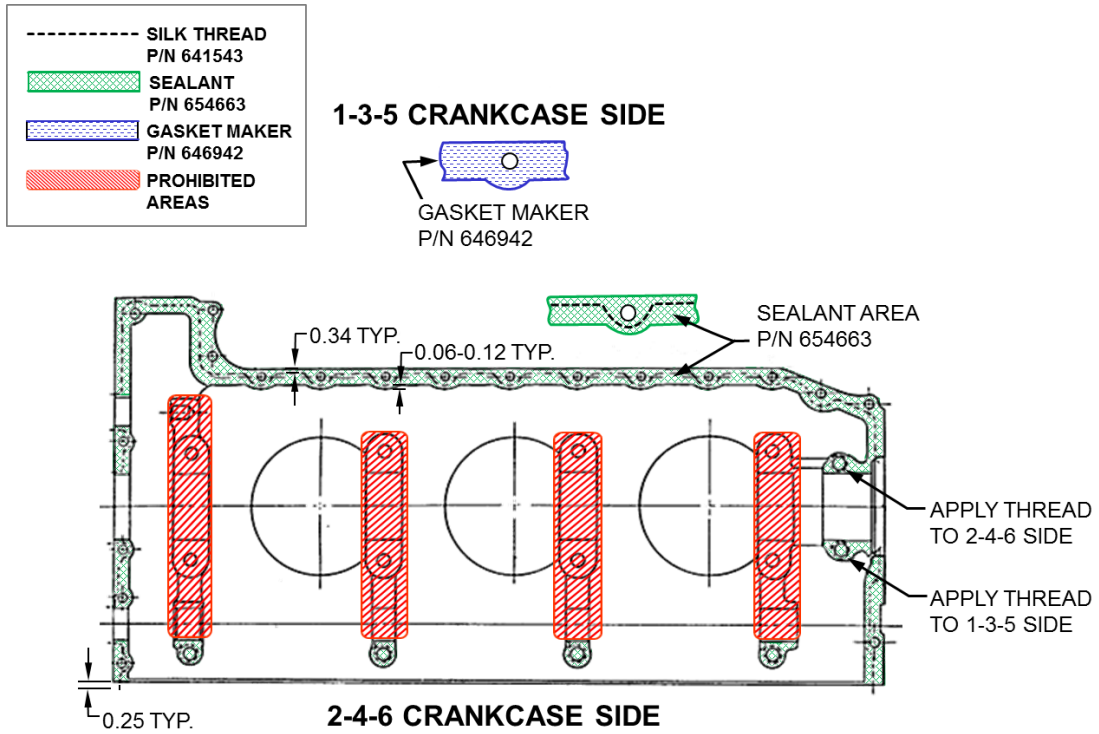

Figure 7. Threading Diagram, O470, IO470, LIO520, LTSIO520, IO550 Sandcast Crankcase

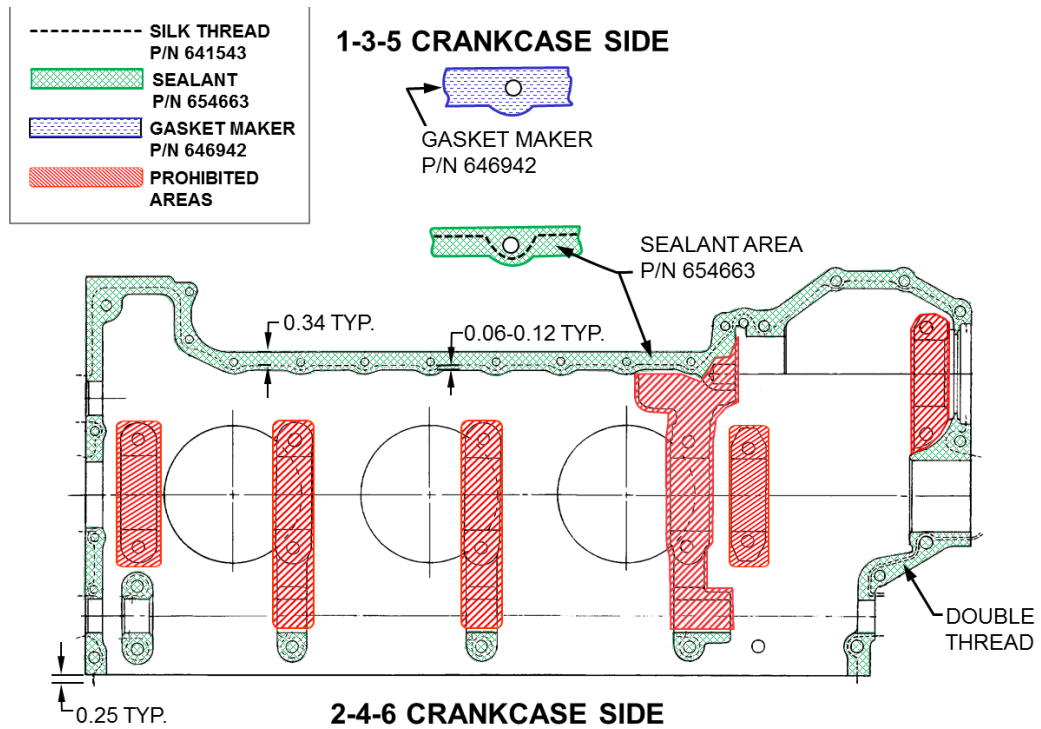

Figure 8. Threading Diagram, GTSIO520 Crankcase

ISSUED	REVISED	 P.O. Box 90 Mobile, AL 251-436-8299	PAGE NO	DOC NO	REVISION
1999/03/29	2014/09/16		16 of 22	SIL99-2	C



### C. Sealant and Threading Procedure for Scavenger Pump Bodies

1. Use full strength, non-thinned P/N 654663 (gasket sealant). Shake or mix well before using.

*CAUTION: Apply gasket sealant and threading (a continuous, single piece) only as illustrated.*

2. Apply gasket sealant per the manufacturer's instructions only in areas where threading is indicated. When applying, use short light brush strokes until an even thin coat is obtained. The gasket sealant should be viscous enough that most of the brush marks disappear; if not, remove old gasket sealant and reapply with new gasket sealant.

NOTE: Allow the gasket sealant to air dry to a tacky condition before applying silk threading.

3. Apply a thin translucent coat of P/N 654942 (gasket maker), not to exceed 0.010 inch thick in all areas that will mate against areas where gasket sealant was applied on the matching surfaces.
4. Apply P/N 641543 (a continuous, single piece of grade "D" silk thread) as shown by the dashed lines in Figure 9.
5. Assemble and torque as soon as possible in accordance with the applicable overhaul manual.

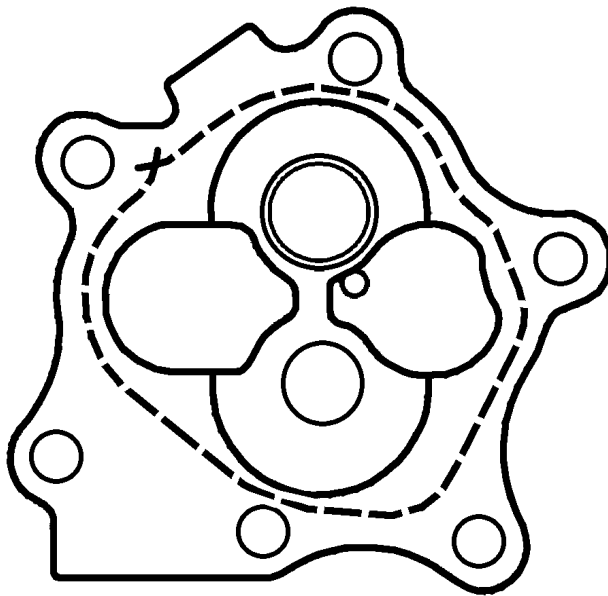

Figure 9. Threading Diagram, Scavenge Pump Bodies 640741, 652019, 652019, & 655713  
(used on starter adapters 642087 & corresponding 0.015 oversize adapters)

ISSUED	REVISED	 P.O. Box 90 Mobile, AL 251-436-8299	PAGE NO	DOC NO	REVISION
1999/03/29	2014/09/16		17 of 22	SIL99-2	C

## D. Sealant and Threading Procedure for Oil Pump Assemblies

1. Use full strength, non-thinned P/N 654663 (gasket sealant). Shake or mix well before using.

*CAUTION: Apply gasket sealant and threading (a continuous, single piece) only as illustrated.*

2. Apply gasket sealant per the manufacturer's instructions only in areas where threading is indicated. When applying, use short light brush strokes until an even thin coat is obtained. The gasket sealant should be viscous enough that most of the brush marks disappear; if not, remove old gasket sealant and reapply with new gasket sealant.

NOTE: Allow the gasket sealant to air dry to a tacky condition before applying silk threading.

3. Apply a thin translucent coat of P/N 654942 (gasket maker), not to exceed 0.010 inch thick in all areas that will mate against areas where gasket sealant was applied on the matching surfaces.
4. Apply P/N 641543 (a continuous, single piece of grade "D" silk thread) as shown by the dashed lines in Figures 10 through 14, pages 18-20).
5. Assemble and torque as soon as possible in accordance with the applicable overhaul manual.

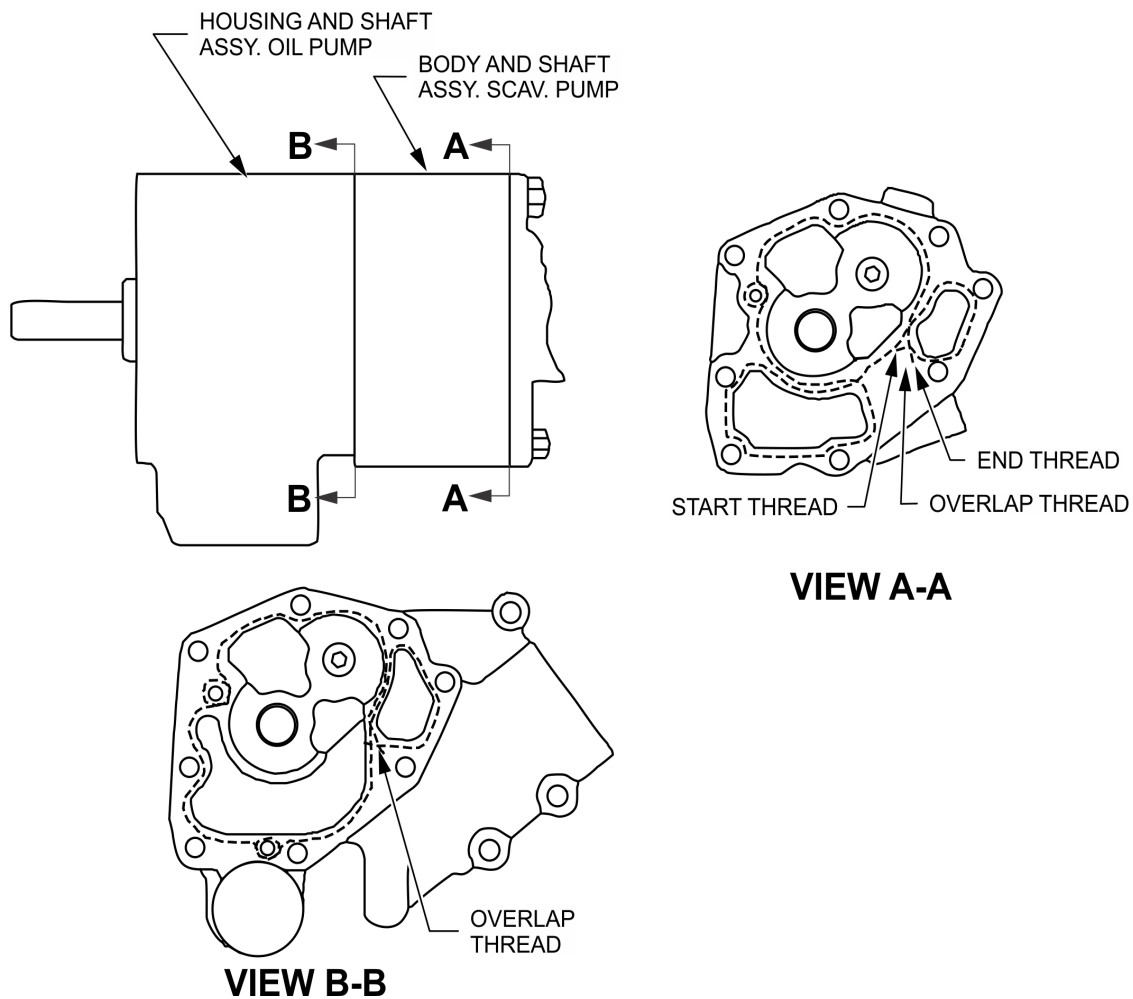

Figure 10. Threading Diagram, Oil Pump Assembly 632623

ISSUED	REVISED	 P.O. Box 90 Mobile, AL 251-436-8299	PAGE NO	DOC NO	REVISION
1999/03/29	2014/09/16			18 of 22	SIL99-2

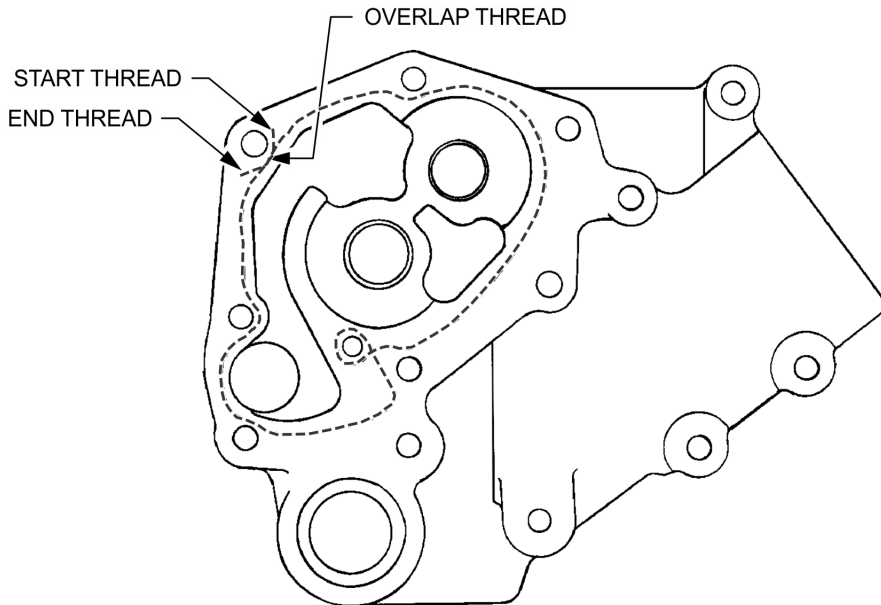

Figure 11. Threading Diagram, Oil Pump Assembly 631713, 632481, 632563, & 641993

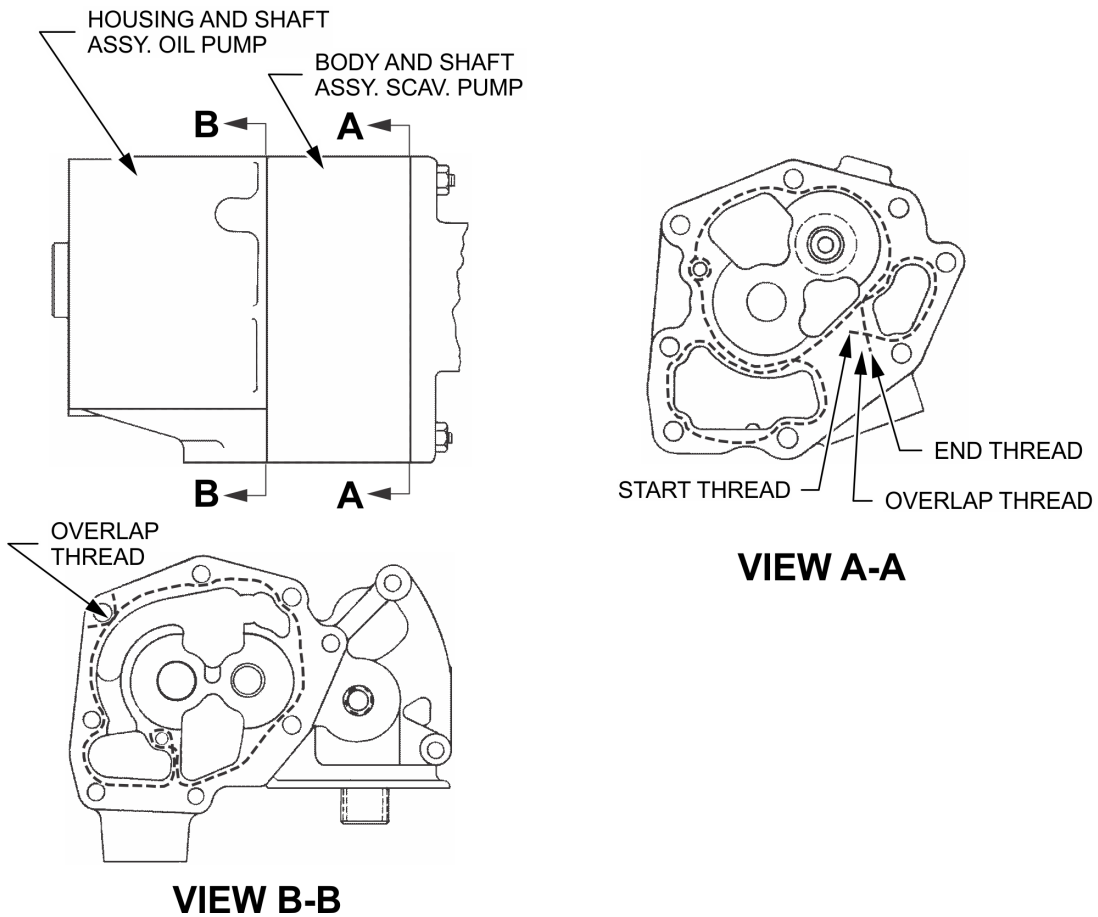

Figure 12. Threading Diagram, Oil Pump Assemblies 646194, 653536, 655121, & 643527

ISSUED	REVISED	 P.O. Box 90 Mobile, AL 251-436-8299	PAGE NO	DOC NO	REVISION
1999/03/29	2014/09/16		19 of 22	SIL99-2	C

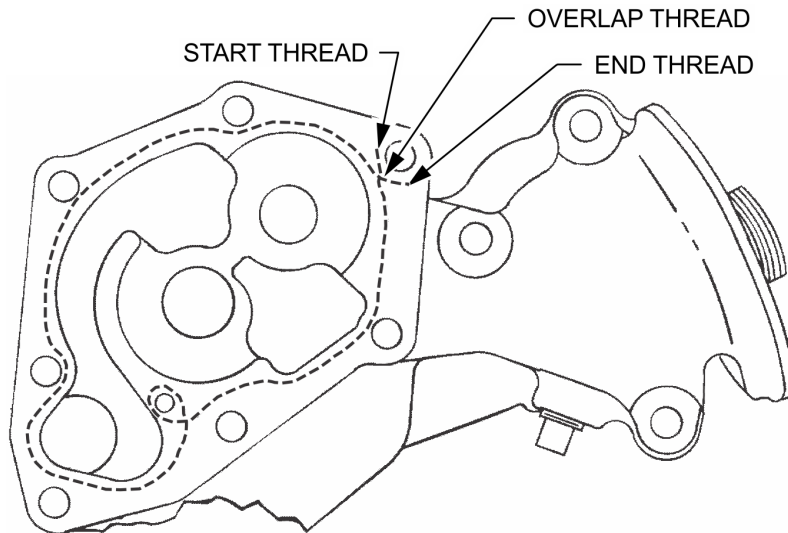

Figure 13. Threading Diagram, Oil Pump Assemblies 643716, 643717, 643743, 643778, 643779, 653494, 653538, 653542, 653542, 653553, 655117, 655119, 655123, 655124, & 655127

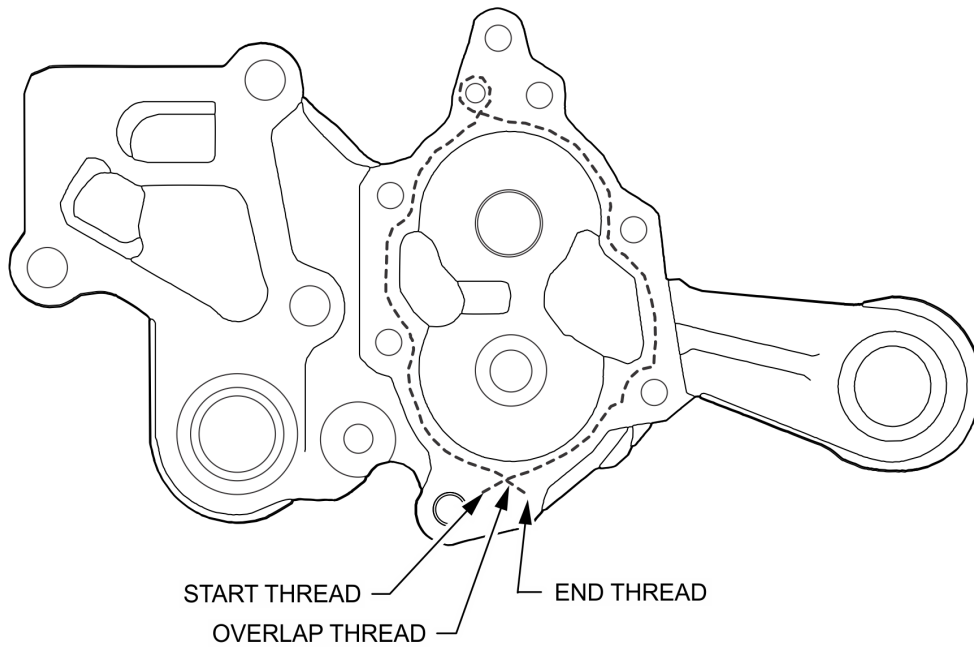

Figure 14. Threading Diagram, Oil Pump Assemblies 631149, 632970, 632977, 654437, 655349, & 655680

ISSUED	REVISED	 P.O. Box 90 Mobile, AL 251-436-8299	PAGE NO	DOC NO	REVISION
1999/03/29	2014/09/16		20 of 22	SIL99-2	C

## E. Sealant and Threading Procedure for Starter Adapter Assemblies

1. Use full strength, non-thinned P/N 654663 (gasket sealant). Shake or mix well before using.

*CAUTION: Apply gasket sealant and threading (a continuous, single piece) only as illustrated.*

2. Apply gasket sealant per the manufacturer's instructions only in areas where threading is indicated. When applying, use short light brush strokes until an even thin coat is obtained. The gasket sealant should be viscous enough that most of the brush marks disappear; if not, remove old gasket sealant and reapply with new gasket sealant.

**NOTE:** Allow the gasket sealant to air dry to a tacky condition before applying silk threading.

3. Apply a thin translucent coat of P/N 654942 (gasket maker), not to exceed 0.010 inch thick in all areas that will mate against areas where gasket sealant was applied on the matching surfaces.
4. Apply P/N 641543 (a continuous, single piece of grade "D" silk thread) as shown by the dashed lines in Figure 15.
5. Assemble and torque as soon as possible in accordance with the applicable overhaul manual.

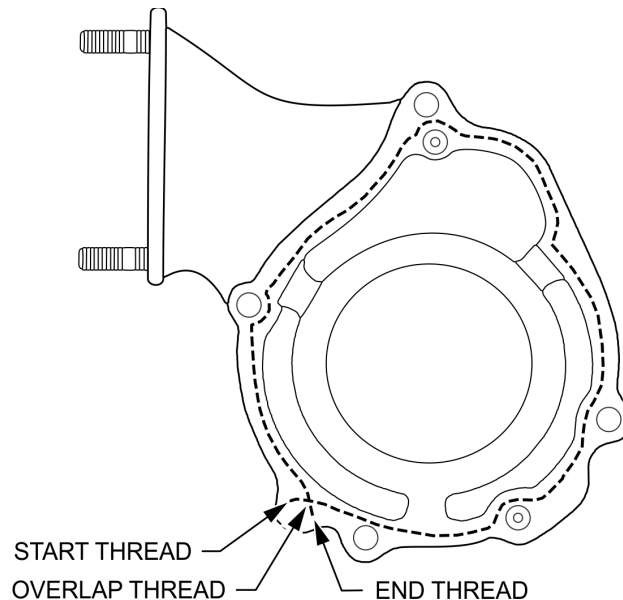

**Figure 15. Threading Diagram, Starter Adapter Assemblies 641348, 646220, & 653074**

ISSUED	REVISED	 P.O. Box 90 Mobile, AL 251-436-8299	PAGE NO	DOC NO	REVISION
1999/03/29	2014/09/16		21 of 22	SIL99-2	C

## F. Sealant and Threading Procedure for Accessory Starter Drive Adapter Assemblies

1. Use full strength, non-thinned P/N 654663 (gasket sealant). Shake or mix well before using.

*CAUTION: Apply gasket sealant and threading (a continuous, single piece) only as illustrated.*

2. Apply gasket sealant per the manufacturer's instructions only in areas where threading is indicated. When applying, use short light brush strokes until an even thin coat is obtained. The gasket sealant should be viscous enough that most of the brush marks disappear; if not, remove old gasket sealant and reapply with new gasket sealant.

**NOTE:** Allow the gasket sealant to air dry to a tacky condition before applying silk threading.

3. Apply P/N 641543 (a continuous, single piece of grade "D" silk thread) as shown by the dashed lines in Figure 16.
4. Temporarily install the starter adapter to make an impression of the thread on the accessory case.
5. Carefully remove the starter adapter so that the shaft gear does not pull out.
6. Inspect the thread impression for 100% contact between the adapter and accessory case.
7. Wipe excess gasket maker off of accessory case and install starter adapter in accordance with the applicable overhaul instructions.

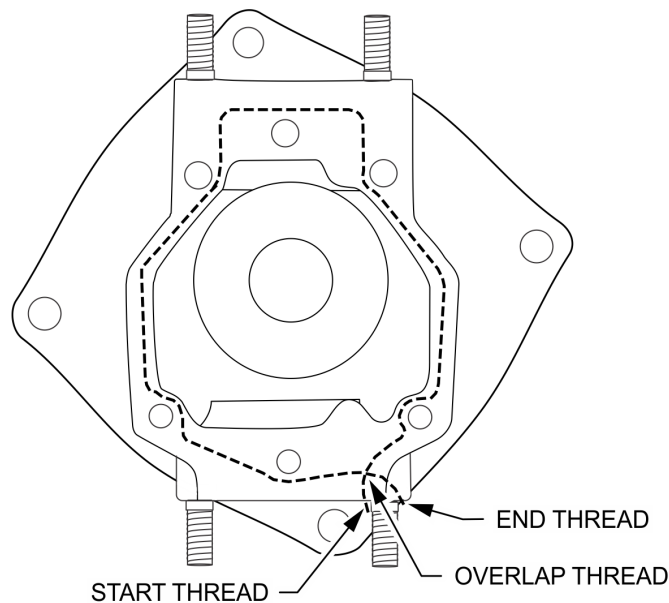

**Figure 16. Threading Diagram, Accessory Starter Drive Adapter Assemblies 641348 & 653074**

ISSUED	REVISED		PAGE NO	DOC NO	REVISION
1999/03/29	2014/09/16	P.O. Box 90 Mobile, AL 251-436-8299	22 of 22	SIL99-2	C